



HIGHLANDS RIVERFRONT

DUPLEX INTERIOR FINISH SELECTIONS



HIGHLANDS RIVERFRONT DESIGN PACKAGES HAVE BEEN EXCLUSIVELY SELECTED BY CORE PROJECT STUDIOS AND ARE THE PROPERTY OF CORE PROJECT STUDIOS. REUSE OR REPRODUCTION IS PROHIBITED WITHOUT WRITTEN CONSENT OF DESIGNER. SELECTIONS SUBJECT TO CHANGE BASED ON AVAILIBLTY.

HIGHLANDS RIVERFRONT DUPLEX MAIN LIVING AREA

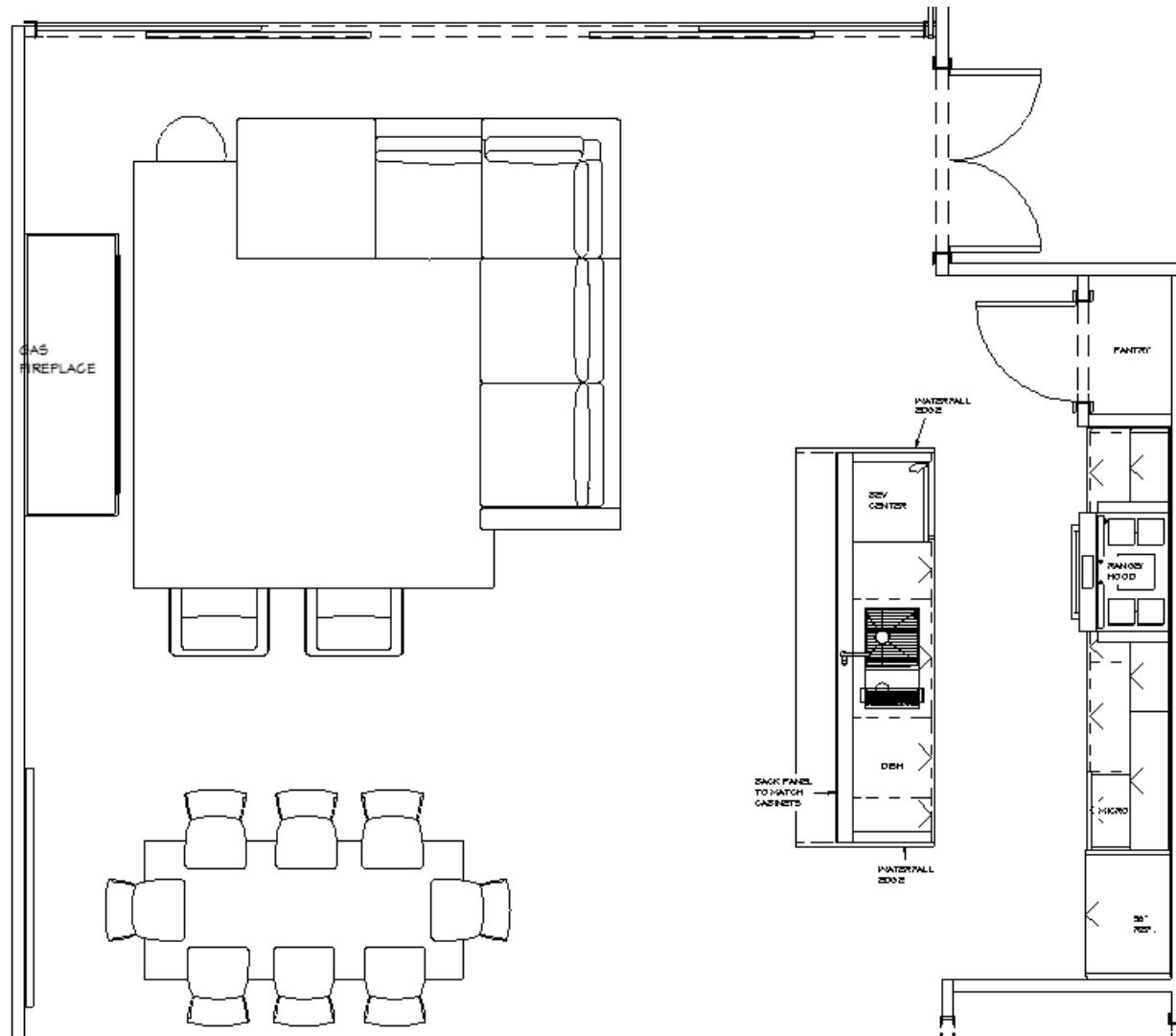

HIGHLANDS RIVERFRONT DUPLEX MAIN LIVING AREA

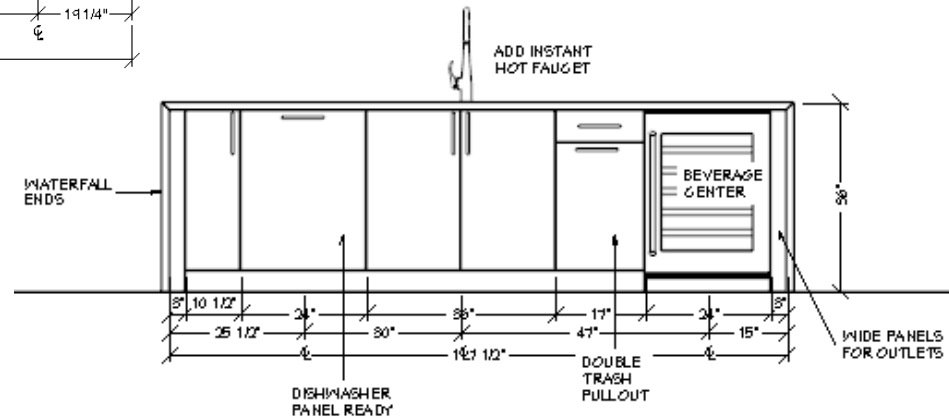
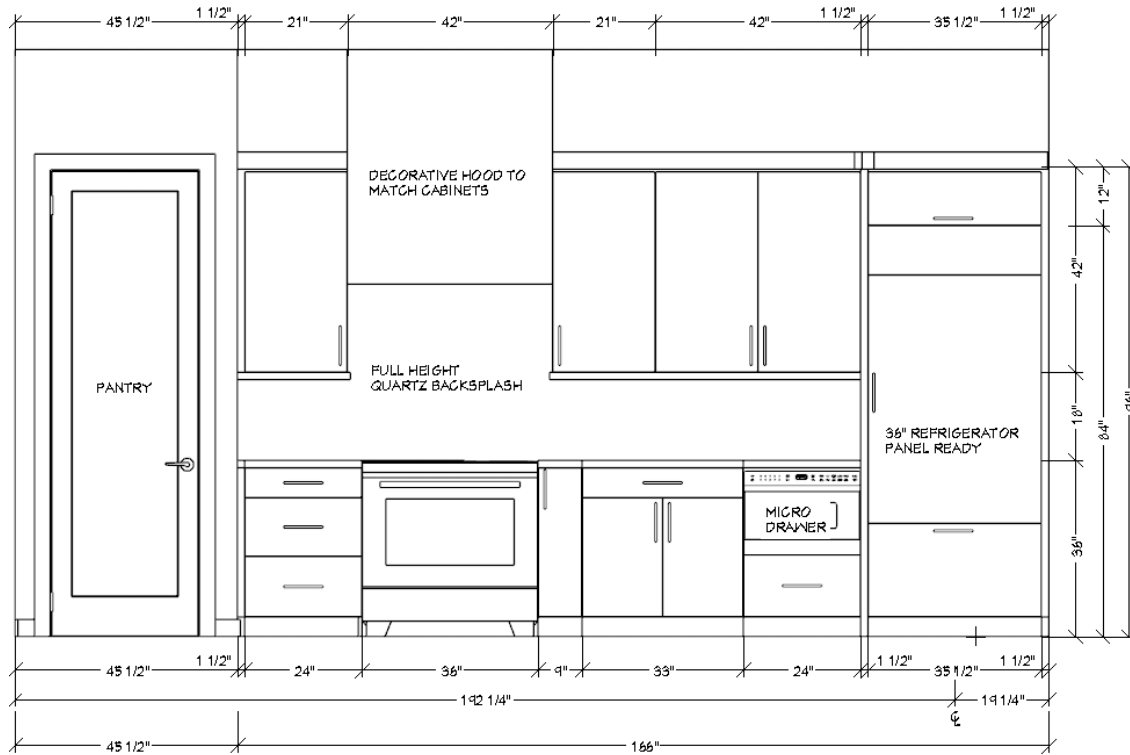

HIGHLANDS RIVERFRONT DUPLEX
MAIN LIVING AREA
STANDARD APPLIANCES



36" BUILT IN REFRIGERATOR
PANEL READY



36" INDUCTION RANGE
STAINLESS



40" HOOD LINER
WARRPED TO MATCH CABINETS



24" MICROWAVE DRAWER
STAINLESS



24" DISHWASHER
PANEL READY



24" BEVERAGE CENTER
PANEL READY

HIGHLANDS RIVERFRONT DUPLEX MAIN LIVING AREA OPTION 1



SCHEUCHER OAK COUNTRY
LACOSTE



PAINTED WHITE
SHAKER

PAINTED WHITE SLAB

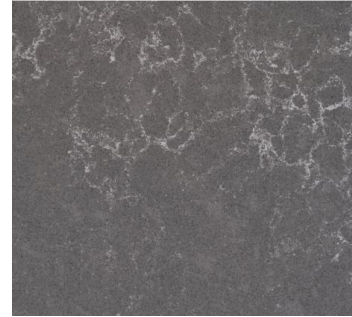

HANSTONE QUARTZ
EMBRACE 3CM
EASED EDGE



GRACE MATTE BLACK

GRACE AGED BRASS



QUARTZ SURROUND
HANSTONE YORKVILLE



JONI MATTE BLACK

JONI AGED BRASS



Kohler Crue Pull-down
Matte Black Finish



EMTEK WARWICK PULL 6"
Flat Black Finish



Kohler Cairn Double Bowl
Matte Black Finish

HIGHLANDS RIVERFRONT DUPLEX
MAIN LIVING AREA
OPTION 2



SCHEUCHER OAK COUNTRY
PERLA



ALDER SHAKER
EBONY OR ESPRESSO

ALDER VENEER SLAB
EBONY OR ESPRESSO



HANSTONE QUARTZ
CALACATTA EXTRA 3CM
EASED EDGE

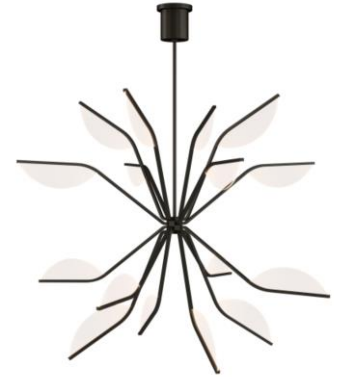

BELTERRA BLACK



METAL SURROUND



KAI BLACK



Kohler Purist Semi-Pro
Vibrant Stainless Finish



EMTEK EDGE PULL 6"
Flat Black Finish



Kohler Strive Single Bowl
Stainless

HIGHLANDS RIVERFRONT DUPLEX
MAIN LIVING AREA
OPTION 3



SCHEUCHER OAK COUNTRY
BIANCA



ALDER SHAKER
SMOKE

ALDER VENEER SLAB
SMOKE



HANSTONE QUARTZ
MERCER 3CM
EASED EDGE



GREYSON BRUSHED NICKEL



QUARTZ SURROUND
HANSTONE UPTOWN GRAY LEATHER



CLARKE POLISHED NICKEL



Kohler Grace Pull-down
Vibrant Stainless Finish



EMTEK FREESTONE PULL 6"
86455US15
Satin Nickel Finish



Kohler Strive Smart Divide
Stainless

HIGHLANDS RIVERFRONT DUPLEX MAIN LIVING AREA AVAILABLE UPGRADE OPTIONS



ADD 2 ROLLOUTS TO BASE CABINETS NEXT TO RANGE



ADD INSTA-HOT FAUCET
Satin Nickel Finish



ADD INSTA-HOT FAUCET
Matte Black Finish

ADD 15" DEEP STORAGE CABINETS ON BACK OF ISLAND
*EXPANDING ISLAND REDUCES CLEARANCE TO LIVING SPACE



ADD POT FILLER
Vibrant Stainless Finish



ADD POT FILLER
Matte Black Finish

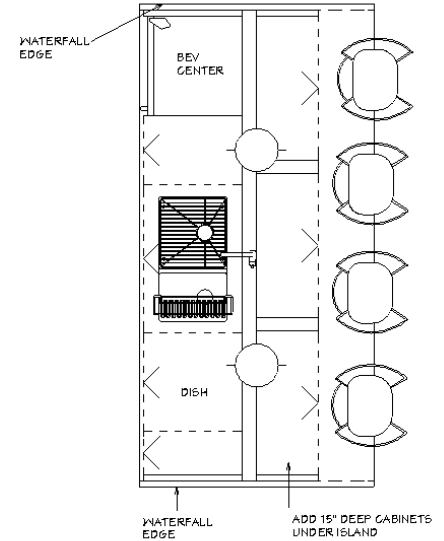
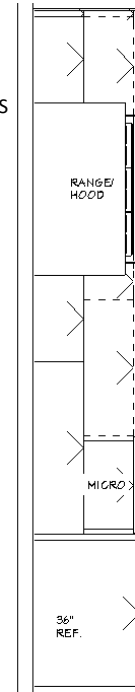

36" DUAL FUEL RANGE WITH 6 BURNERS



48" DUAL FUEL RANGE WITH 6 BURNERS AND GRIDDLE WITH MATCHING HOOD LINER



RECLAIMED WOOD FLOORING

HIGHLANDS RIVERFRONT DUPLEX POWDER BATH

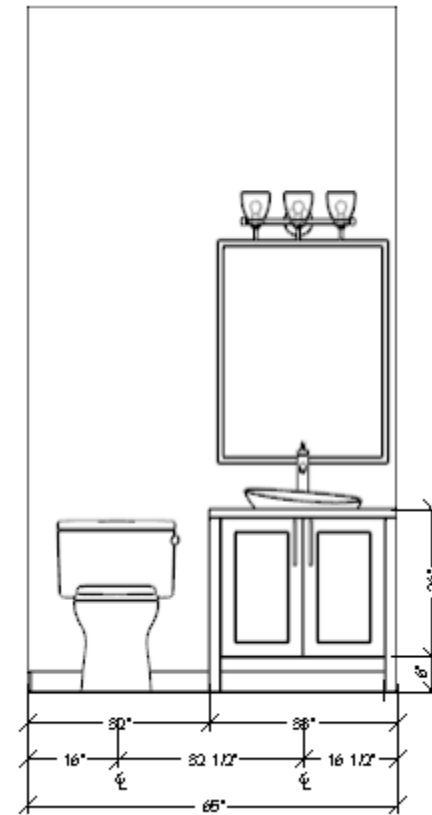
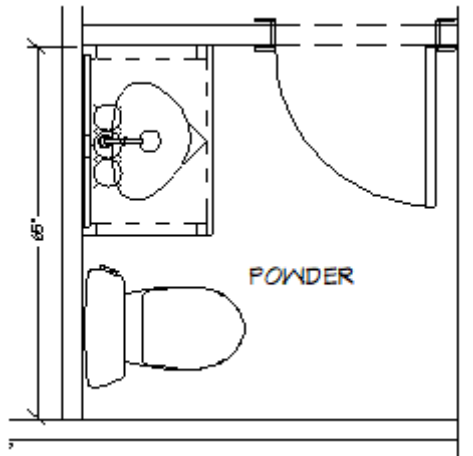

HIGHLANDS RIVERFRONT DUPLEX
TOILETS
ALL BATHROOMS



KOHLER BETELLO
WHITE FINISH

TRIP LEVER TO MATCH BATHROOM FINISH



KOHLER BETELLO
BRUSHED NICKEL FINISH



KOHLER BETELLO
MATTE BLACK FINISH

HIGHLANDS RIVERFRONT DUPLEX POWDER BATH OPTION 1



PAINTED WHITE
SHAKER

PAINTED WHITE SLAB



HANSTONE QUARTZ
AWAKEN 3CM
EASED EDGE



FILMORE CHROME/BLACK



FEISS KIT POLISHED NICKEL



EMTEK FREESTONE PULL 6"
Polished Chrome Finish



KOHLER PURIST TALL
Polished Chrome Finish



KOHLER BRAZEN
White Finish



KOHLER PURIST
Polished Chrome Finish



KOHLER PURIST
Polished Chrome Finish

HIGHLANDS RIVERFRONT DUPLEX
POWDER BATH
OPTION 2



ALDER SHAKER
EBONY OR ESPRESSO



ALDER VENEER SLAB
EBONY OR ESPRESSO



HANSTONE QUARTZ
DRIFT 3CM
EASED EDGE



CAPITAL BLACK



FRAMED BLACK/BRASS



EMTEK WARWICK T KNOB
Flat Black Finish



KOHLER PARALLEL TALL
Matte Black Finish



KOHLER VEIL
White Finish



KOHLER PARALLEL
Matte Black Finish



KOHLER PARALLEL
Matte Black Finish

HIGHLANDS RIVERFRONT DUPLEX
POWDER BATH
OPTION 3



ALDER SHAKER
SMOKE



ALDER VENEER SLAB
SMOKE



HANSTONE QUARTZ
CALACATTA VENATO 3CM
EASED EDGE



LANGFORD SATIN NICKEL



HENDRIK BRUSHED NICKEL



EMTEK TRAIL PULL 6"
Satin Nickel Finish



KOHLER AVID TALL
Brushed Nickel
Finish



KOHLER DERRING
Translucent White
Finish



KOHLER AVID
Brushed Nickel
Finish



KOHLER AVID
Brushed Nickel
Finish

HIGHLANDS RIVERFRONT DUPLEX PRIMARY BATH

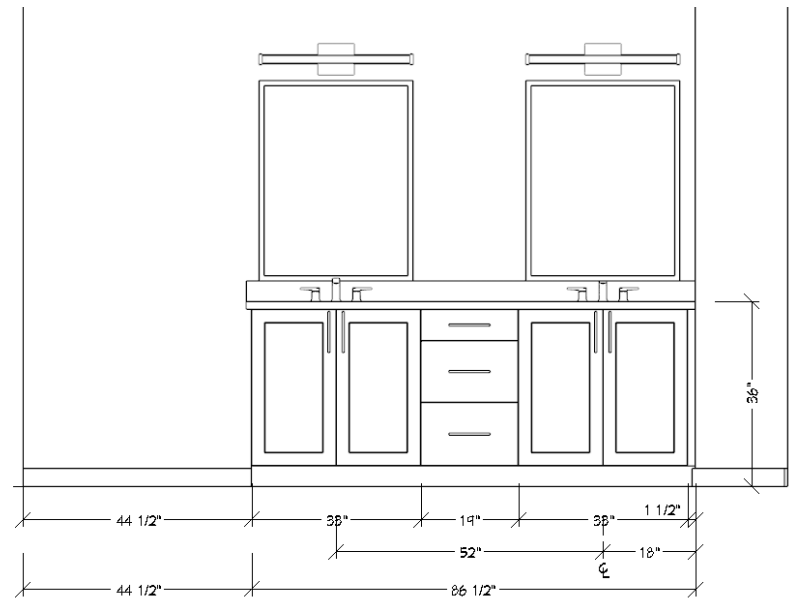
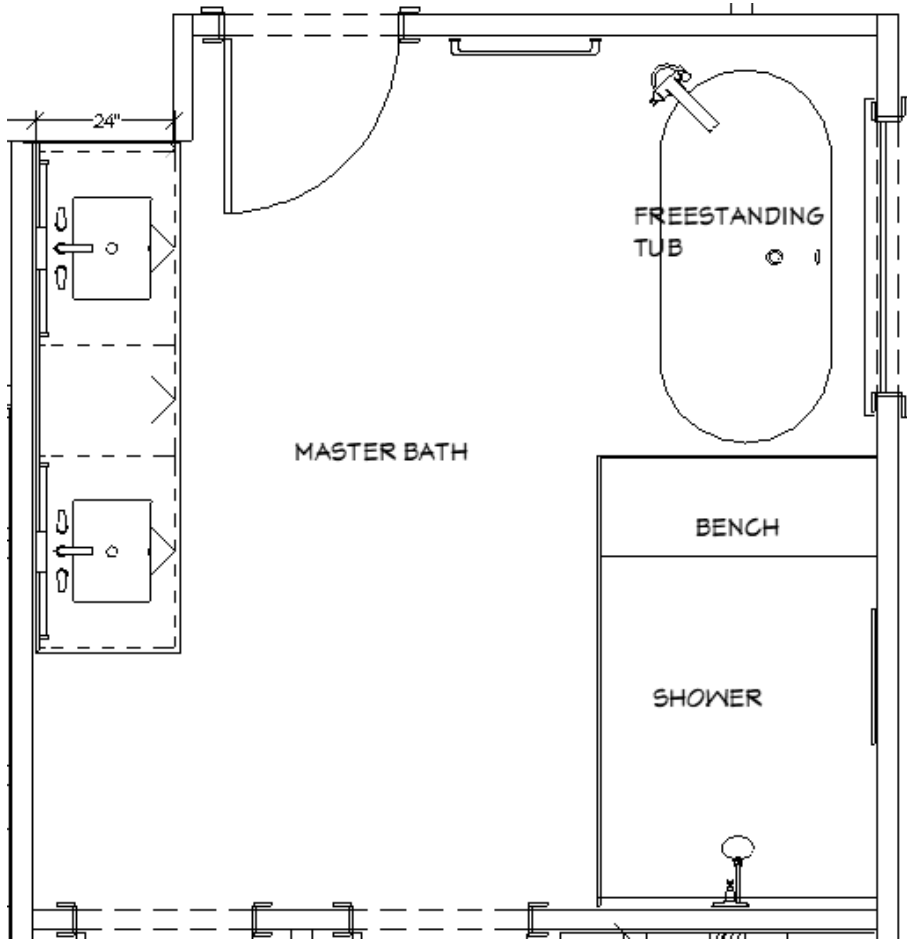

HIGHLANDS RIVERFRONT DUPLEX PRIMARY BATH OPTION 1



PAINTED WHITE
SHAKER

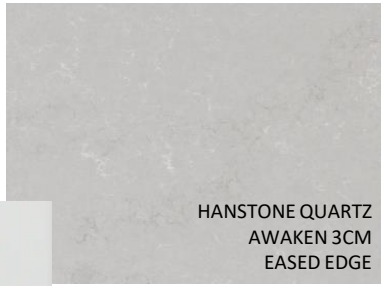

HANSTONE QUARTZ
AWAKEN 3CM
EASED EDGE

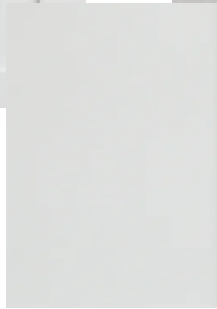

PAINTED WHITE SLAB



EMTEK CADET KNOB
Polished Chrome Finish



GENEVA POLISHED NICKEL
QTY OF 2



FLOOR TILE
HOME TURF BIANCO 12X24
PAN 2X2 MOSAIC
GROUT BLEACHED WOOD



KOHLER LADENA
QTY OF 2 White
Finish



KOHLER PURIST WIDESPREAD
Polished Chrome Finish

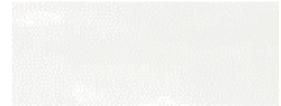

SHOWER WALL TILE
SPICES VANILLA BEAN 8X24
GROUT BRIGHT WHITE



KOHLER HOTEL
Polished Chrome Finish



KOHLER PURIST
Polished Chrome Finish



KOHLER PURIST
Polished Chrome Finish



WYNDHAM REBECCA 60"
White/Polished Chrome Finish



KOHLER PURIST - Polished Chrome Finish



ACCENT TILE
REALSTONE LURE MOSAIC 12X12
GROUT BRIGHT WHITE



HIGHLANDS RIVERFRONT DUPLEX PRIMARY BATH OPTION 1 TILE LAYOUT

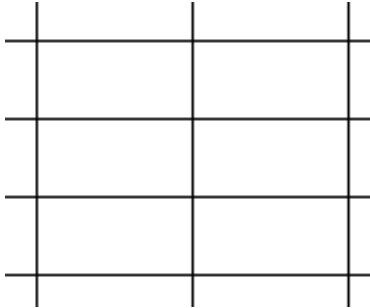

FLOOR TILE 12X24
STRAIGHT SET

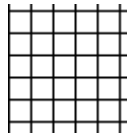

SHOWER PAN 2X2
MOSAIC

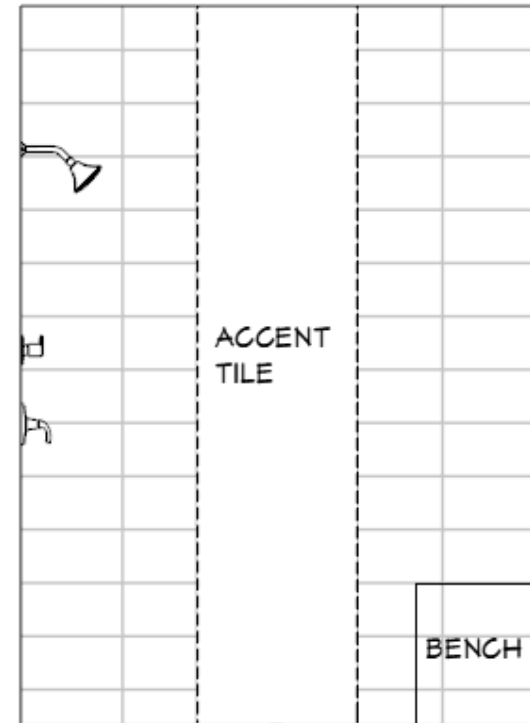
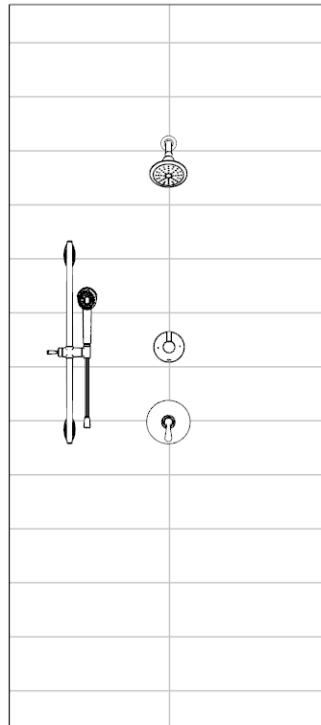

***SCHLUTER TRIM AND PURE CORNER SHELVES TO MATCH PLUMBING FIXTURE FINISH

HIGHLANDS RIVERFRONT DUPLEX PRIMARY BATH OPTION 2



ALDER SHAKER
EBONY OR ESPRESSO

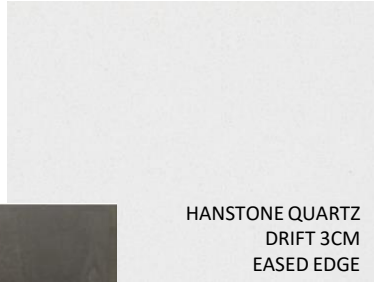

HANSTONE QUARTZ
DRIFT 3CM
EASED EDGE



EOS BLACK
QTY OF 2



FLOOR TILE
BASALTINE LIGHT GRAY 12X24
PAN 2X2 MOSAIC
GROUT GRAYSTONE



ALDER VENEER SLAB
EBONY OR ESPRESSO



EMTEK WARWICK PULL 6"
Flat Black Finish



KOHLER VERTICYL
QTY OF 2 White
Finish



KOHLER PARALLEL WIDESPREAD
QTY OF 2
Matte Black Finish



SHOWER WALL TILE
WOW GRADIENT WHITE GLOSS 3X12
GROUT BRIGHT WHITE



KOHLER AWAKEN
Matte Black Finish



KOHLER PARALLEL
Matte Black Finish



KOHLER PARALLEL
Matte Black Finish



WYNDHAM SARA 59"
White/Black Finish



KOHLER PARALLEL - Matte Black Finish

HIGHLANDS RIVERFRONT DUPLEX
PRIMARY BATH
OPTION 2 TILE LAYOUT

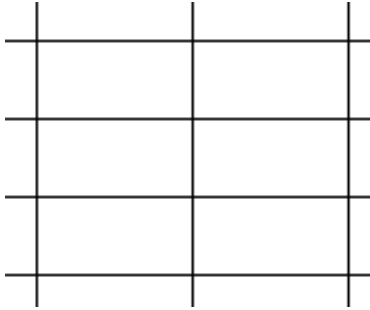

FLOOR TILE 12X24
STRAIGHT SET

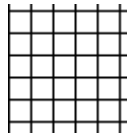

SHOWER PAN 2X2
MOSAIC

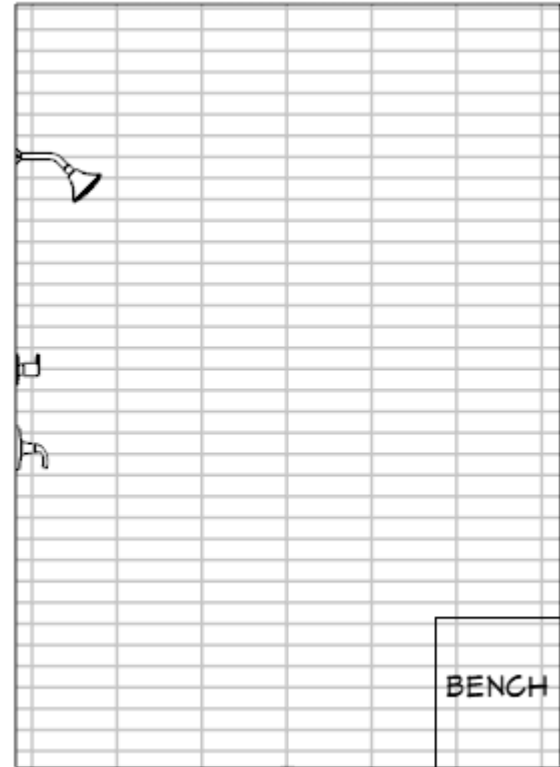
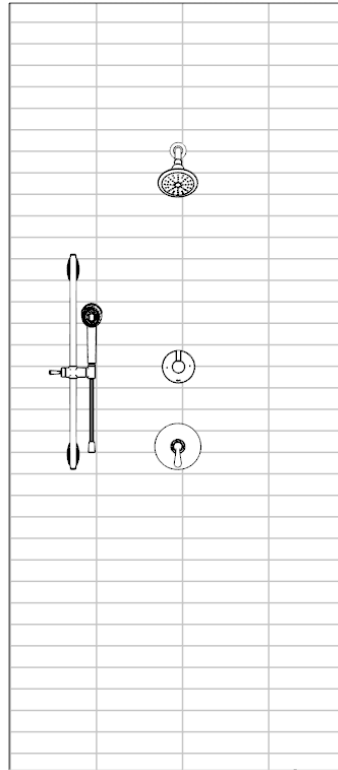

***SCHLUTER TRIM AND PURE CORNER SHELVES TO MATCH PLUMBING FIXTURE FINISH

HIGHLANDS RIVERFRONT DUPLEX PRIMARY BATH OPTION 3



ALDER SHAKER
SMOKE

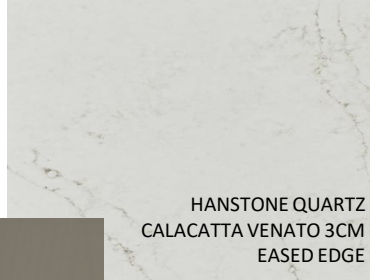

HANSTONE QUARTZ
CALACATTA VENATO 3CM
EASED EDGE



FUSION BRUSHED NICKEL
QTY OF 2



FLOOR TILE
PORTUGAL VELHO WHITE UPS 12X24
PAN 2X2 MOSAIC
GROUT BLEACHED WOOD

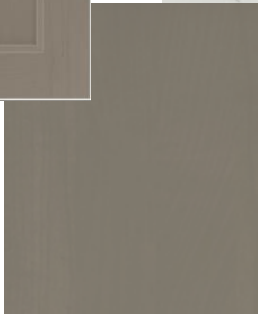

ALDER VENEER SLAB
SMOKE



EMTEK TRAIL PULL 6"
Satin Nickel Finish



KOHLER ARCHER
White Finish



KOHLER AVID WIDESPREAD
QTY OF 2
Brushed Nickel Finish

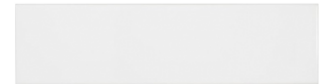

SHOWER WALL TILE
SOHO WHITE GLOSS 4X12
GROUT BRIGHT WHITE



KOHLER FORTE
Brushed Nickel Finish



KOHLER AVID/FORTE
Brushed Nickel Finish



KOHLER AVID
Brushed Nickel
Finish



WYNDHAM TIFFANY 59"
White/Nickel Finish



KOHLER AVID - Brushed Nickel Finish



ACCENT TILE
ELYSIUM CHEVRON BLUE 8X12
GROUT BRIGHT WHITE

HIGHLANDS RIVERFRONT DUPLEX PRIMARY BATH OPTION 3 TILE LAYOUT

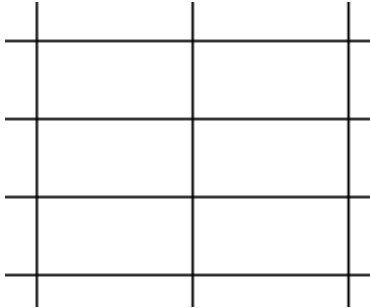

FLOOR TILE 12X24
STRAIGHT SET

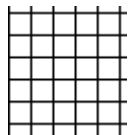

SHOWER PAN 2X2
MOSAIC

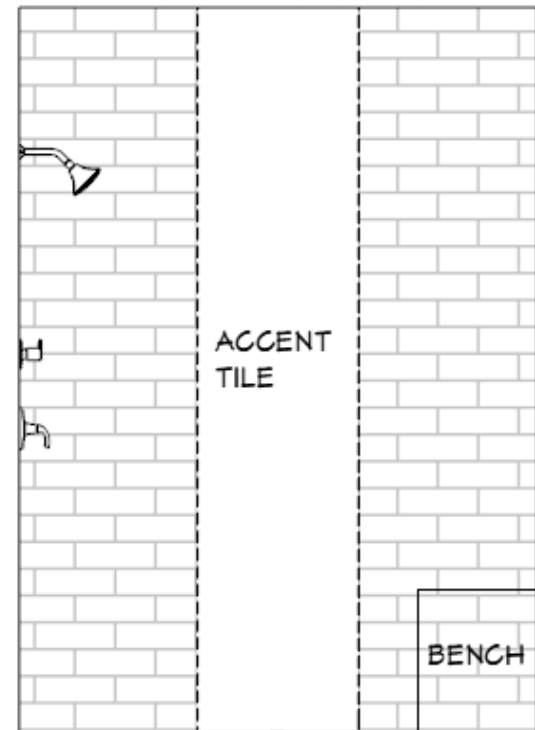
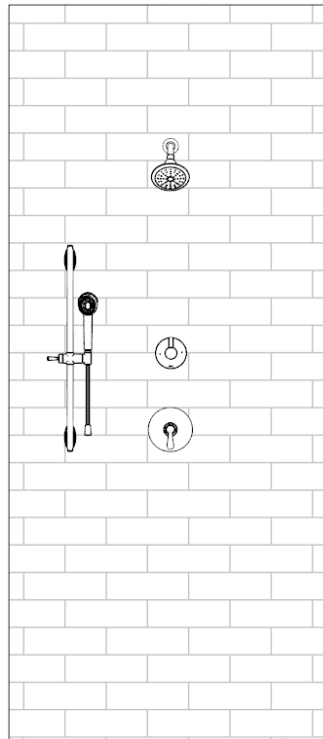

***SCHLUTER TRIM AND PURE CORNER SHELVES TO MATCH PLUMBING FIXTURE FINISH

HIGHLANDS RIVERFRONT DUPLEX PRIMARY SUITE AVAILABLE UPGRADE OPTIONS

UPGRADE TO WOOD FLOORING PRIMARY BEDROOM AND CLOSET STANDARD OR RECLAIMED OPTIONS



SCHEUCHER OAK COUNTRY
LACOSTE



SCHEUCHER OAK COUNTRY
PERLA



SCHEUCHER OAK COUNTRY
BIANCA



RECLAIMED

ADD STEAM SHOWER

*COST WILL VARY DEPENDING ON TILE SELECTION

C³-230
Elongated Bidet Toilet Seat

- Automatic UV Self-Cleaning Wand**
The stainless steel wand automatically rinses itself before and after each use.
- Adjustable Water Temperature and Pressure**
Dial in your perfect clean quickly and easily.
- Front and Rear Wash**
Choose between oscillating and pulsating sprays and front and rear wash for a complete clean.
- Continuous Warm Water**
In-unit heater provides continuous warm water for added comfort.
- Automatic Deodorization**
Carbon filter helps remove unwanted odors.
- Warm Air Dryer**
Adjustable air speed and temperature.
- Heated Seat**
Five temperature settings for personalized comfort.
- Touch-Screen Remote**
Touch-screen remote with two programmable presets to use your favorite settings every time.
- LED Nightlight**
Provides optimal light inside the bowl without disrupting nighttime sleep.
- Easy to Install**
Outlet required; simply plug into outlet and connect to water line with included attachments.

THE BOLD LOOK OF KOHLER



ADD BIDET TOILET SEAT

HIGHLANDS RIVERFRONT DUPLEX
MINI PRIMARY

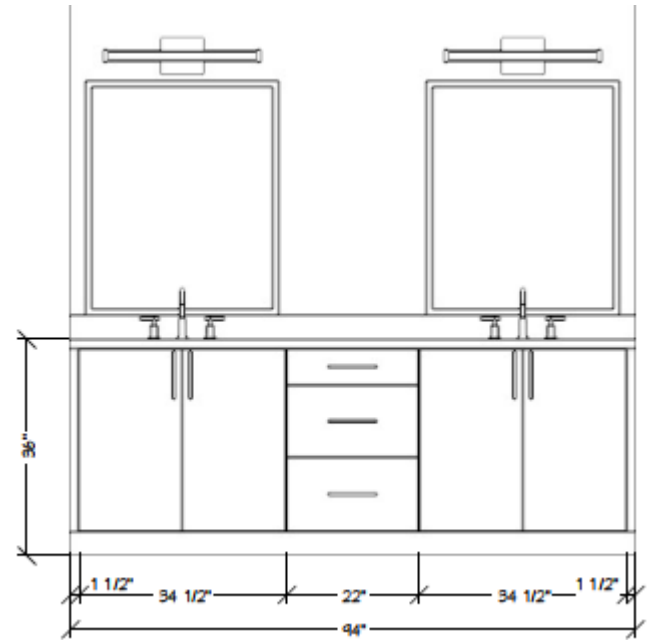
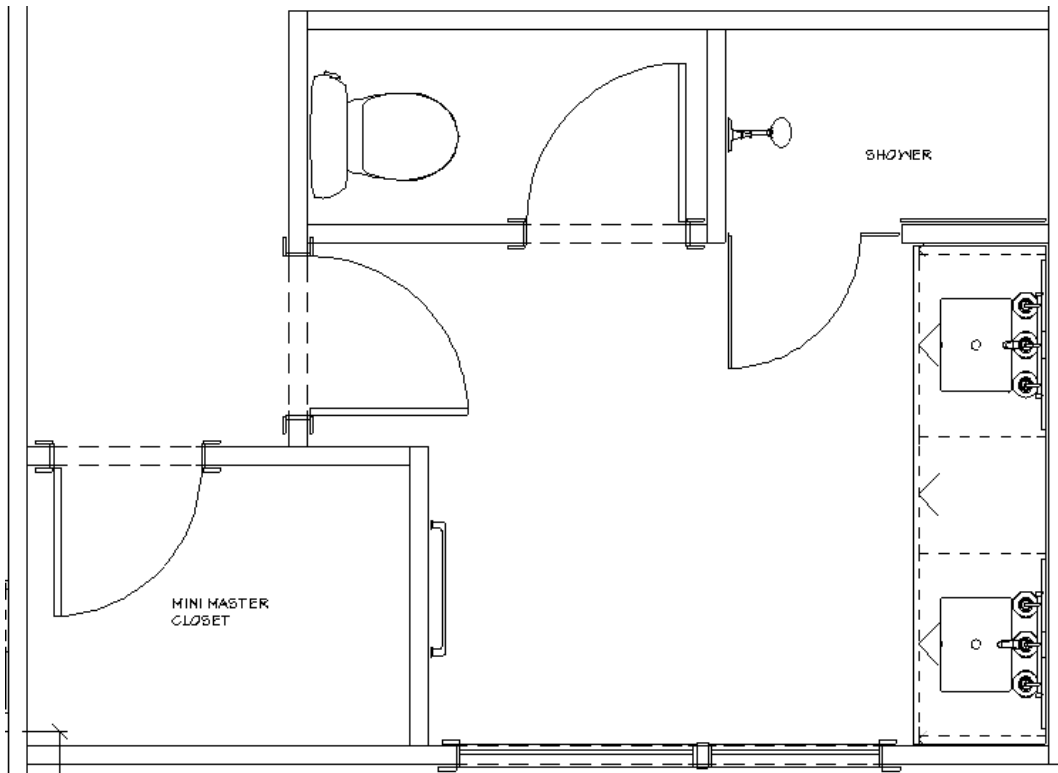

HIGHLANDS RIVERFRONT DUPLEX
GUEST BATH 3

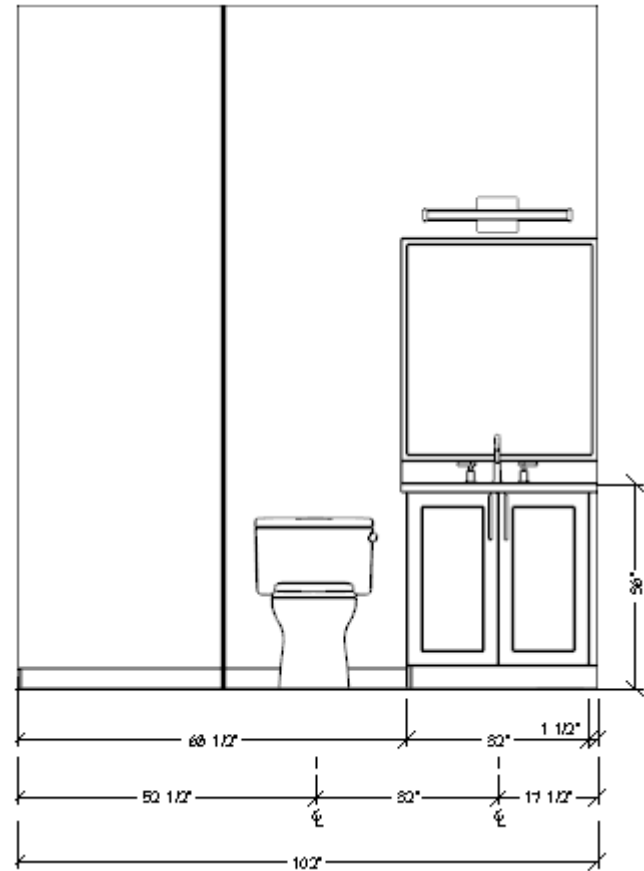
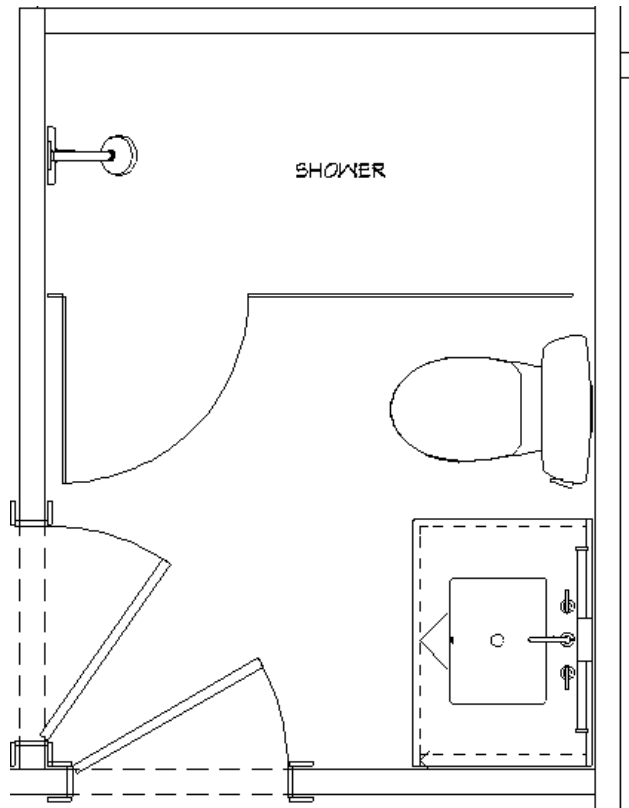

HIGHLANDS RIVERFRONT DUPLEX
GUEST BATH 4

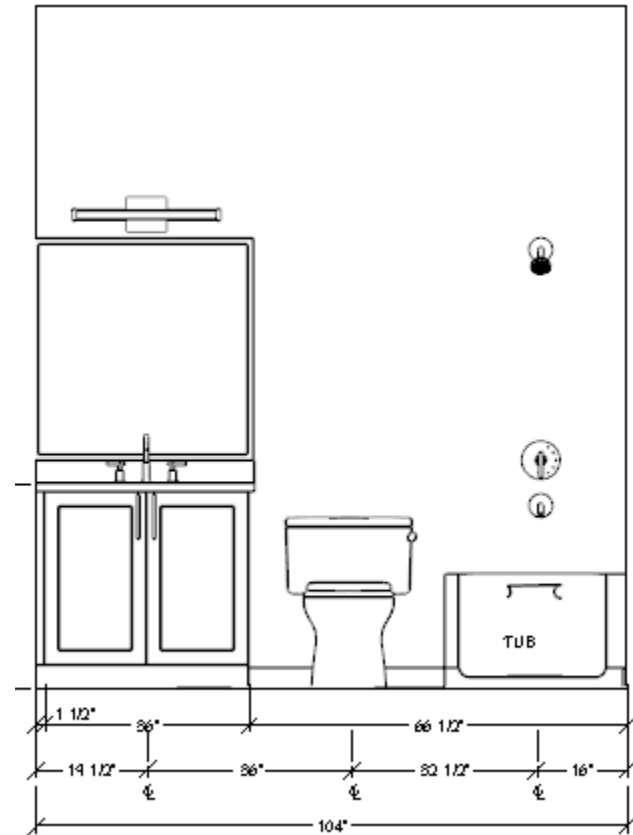
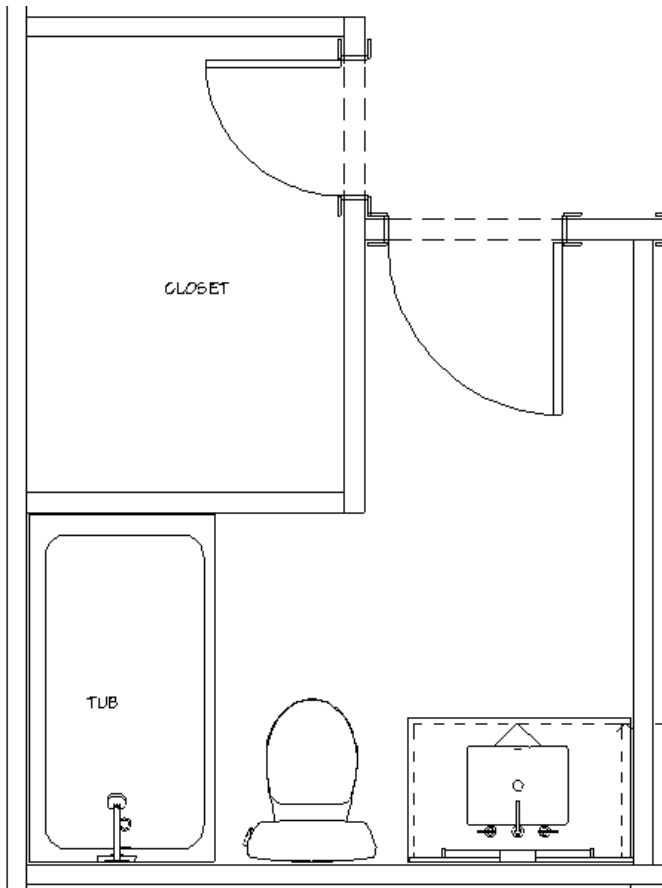

HIGHLANDS RIVERFRONT DUPLEX ALL GUEST BATHS OPTION 1



PAINTED WHITE
SHAKER

PAINTED WHITE SLAB

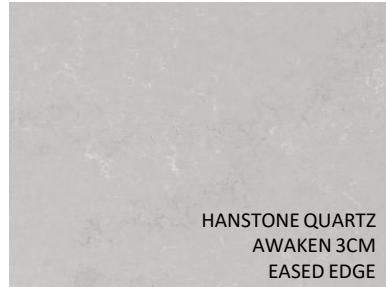

HANSTONE QUARTZ
AWAKEN 3CM
EASED EDGE



EMTEK FREESTONE PULL 6"
Polished Chrome Finish



RILEY POLISHED NICKEL
QTY OF 4

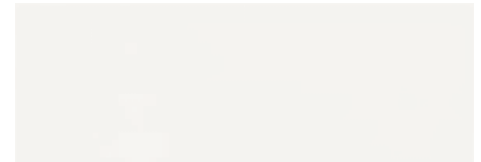

FLOOR
SHADES 2.0 FROST UPS 6X24
GROUT SNOW WHITE



KOHLER PURIST
Polished Chrome Finish



KOHLER PURIST
Polished Chrome Finish



KOHLER LADENA
QTY OF 4 White Finish



KOHLER PURIST SINGLE
QTY OF 4 Polished
Chrome Finish

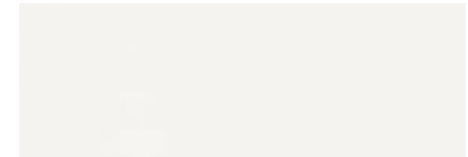

SHOWER WALL TILE
SHADES 2.0 FROST UPS 6X24
GROUT SNOW WHITE



SITKA ALCOVE TUB 60X30
White/Chrome Finish



KOHLER PURIST
Polished Chrome Finish

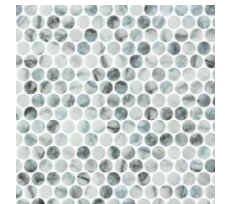

ACCENT AND PAN TILE
VANGUARD PENNY AZUL
12X12 SHEET

HIGHLANDS RIVERFRONT DUPLEX
ALL GUEST BATHS
OPTION 1 TILE LAYOUT

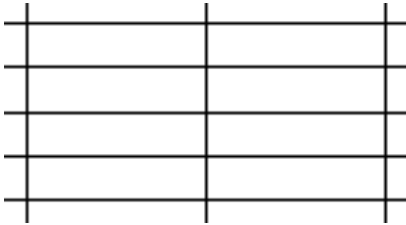

FLOOR TILE 6X24
STRAIGHT SET

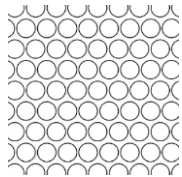

SHOWER PAN PENNY ROUND
MOSAIC

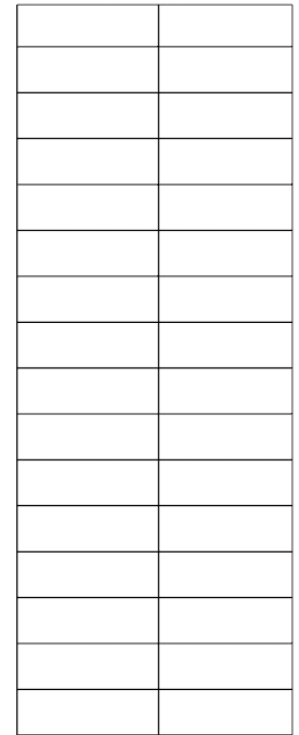
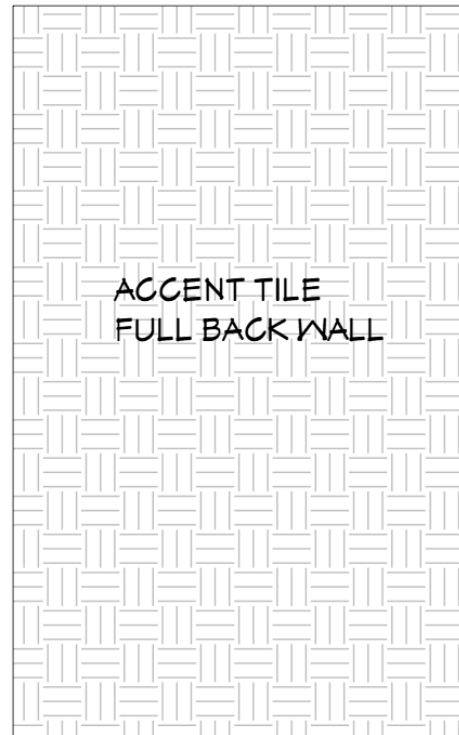
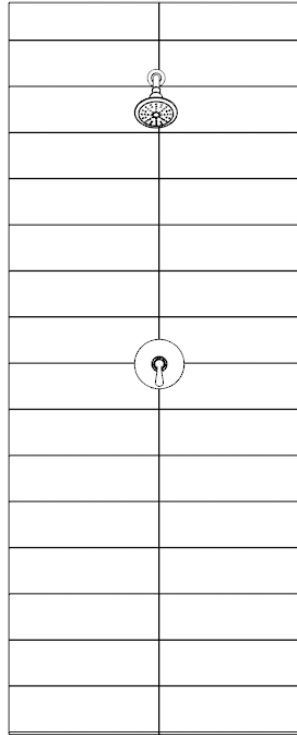

***SCHLUTER TRIM AND PURE CORNER SHELVES TO MATCH PLUMBING FIXTURE FINISH

HIGHLANDS RIVERFRONT DUPLEX

ALL GUEST BATHS

OPTION 2



ALDER SHAKER
EBONY OR ESPRESSO



ALDER VENEER SLAB
EBONY OR ESPRESSO

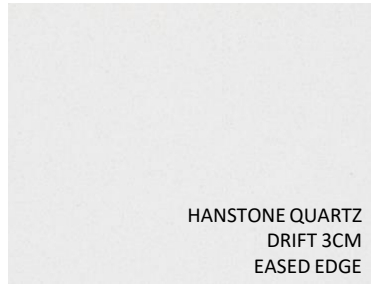

HANSTONE QUARTZ
DRIFT 3CM
EASED EDGE



EMTEK WARWICK T KNOB
Flat Black Finish



MELLER BLACK
QTY OF 4



SHOWER PAN
MULTIPLIER HEX
GRAY MATTE
GROUT TBD

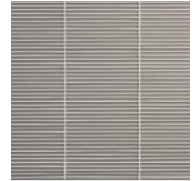

ACCENT TILE
ASTORIA FLUTE STACKED 12X15
MANHATTAN SILK
GROUT SNOW WHITE



SHOWER WALL TILE
LAZY DAZE WHITE 12X24

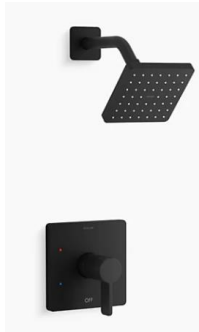

KOHLER PARALLEL
QTY OF 2 Matte Black
Finish



KOHLER PARALLEL
QTY OF 1 Matte Black
Finish



KOHLER VERTICYL
QTY OF 4 White
Finish



KOHLER PARALLEL SINGLE
QTY OF 4 Matte Black
Finish



SITKA ALCOVE TUB 60X30
CONFIRM DRAIN LOCATION
White/Black Finish



KOHLER PARALLEL-
Matte Black Finish

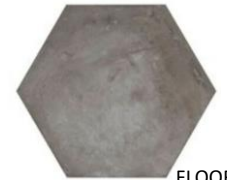

FLOOR TILE
TERRA HEX
ANTRACITE 8 1/2 X 10

HIGHLANDS RIVERFRONT DUPLEX
ALL GUEST BATHS
OPTION 2 TILE LAYOUT

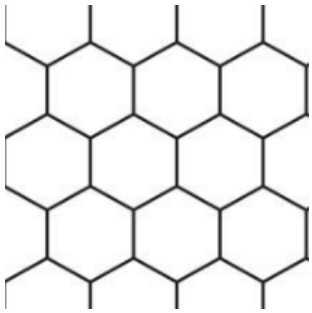

HEXAGON FLOOR

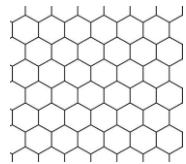

SHOWER PAN
HEXAGON MOSAIC

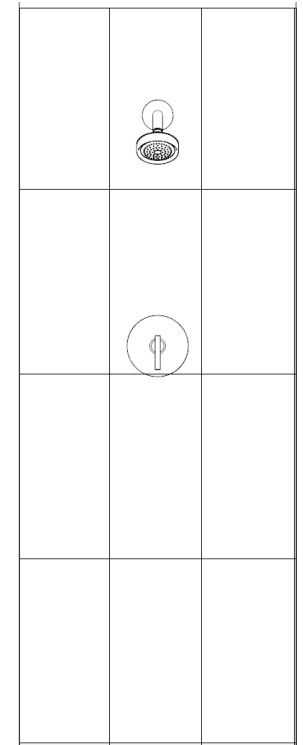
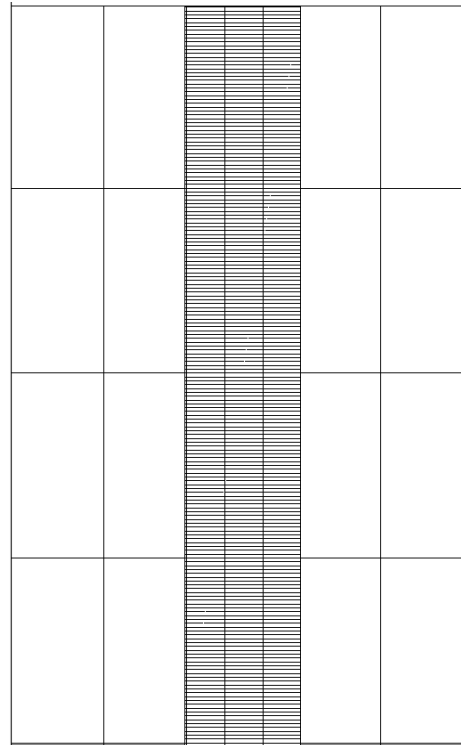
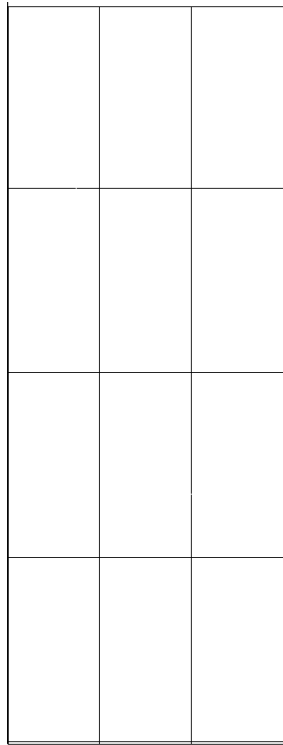

***SCHLUTER TRIM AND PURE CORNER SHELVES TO MATCH PLUMBING FIXTURE FINISH

HIGHLANDS RIVERFRONT DUPLEX

ALL GUEST BATHS

OPTION 3



ALDER SHAKER
SMOKE



ALDER VENEER SLAB
SMOKE



HANSTONE QUARTZ
CALACATTA VENATO 3CM
EASED EDGE



EMTEK TRAIL PULL 6"
Satin Nickel Finish



CARSON SATIN NICKEL
QTY OF 4



PAN TILE
ZEN VITALITY MICA 12X12
GROUT BLEACHED WOOD



KOHLER ARCHER
QTY OF 4 White
Finish



KOHLER AVID SINGLE
QTY OF 4 Brushed
Nickel Finish

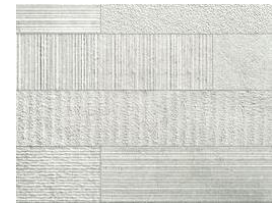

SHOWER WALL TILE
FEEL WHITE DECO BLEND 4X24
GROUT SNOW WHITE



KOHLER AVID/FORTE
Brushed Nickel Finish



KOHLER AVID/FORTE
Brushed Nickel Finish



SITKA ALCOVE TUB 60X30
CONFIRM DRAIN LOCATION
White/Nickel Finish



KOHLER AVID
Brushed Nickel Finish

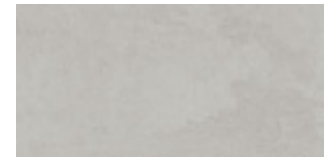

FLOOR TILE
FEEL GRAY 12X24
GROUT GRAYSTONE

HIGHLANDS RIVERFRONT DUPLEX
ALL GUEST BATHS
OPTION 3 TILE LAYOUT

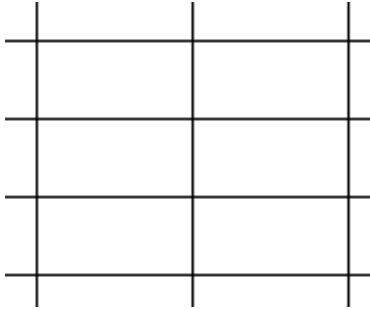

FLOOR TILE 12X24
STRAIGHT SET

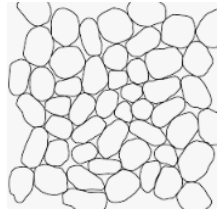

SHOWER PAN
PEBBLE MOSAIC

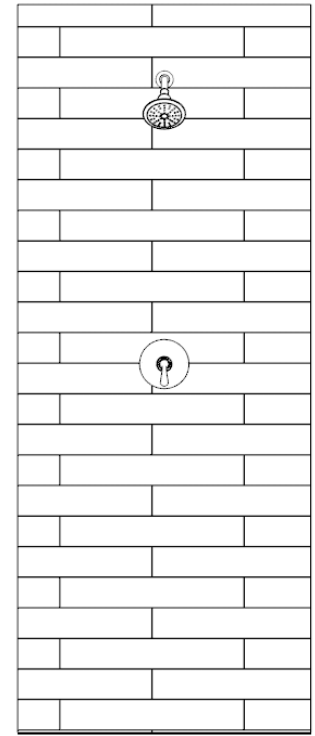
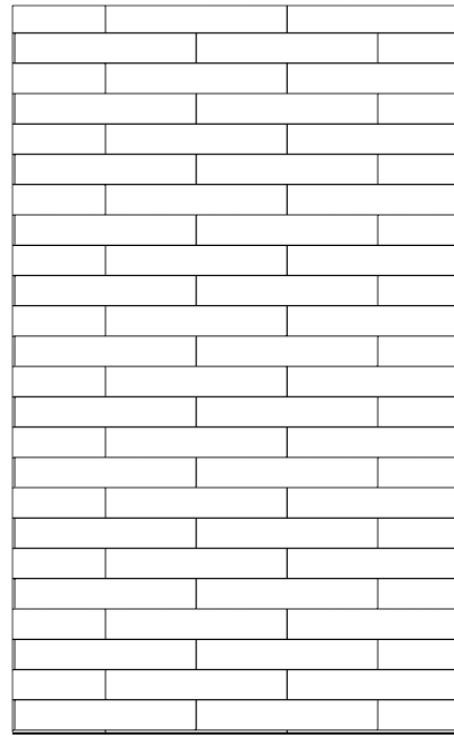
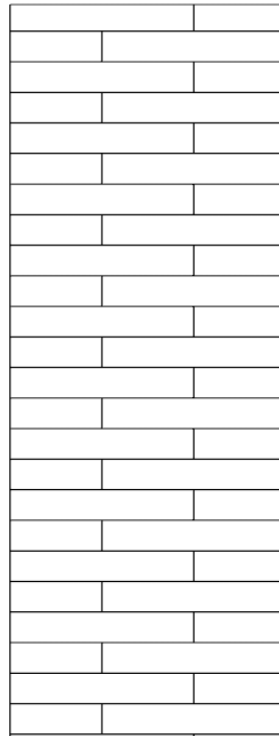

***SCHLUTER TRIM AND PURE CORNER SHELVES TO MATCH PLUMBING FIXTURE FINISH

HIGHLANDS RIVERFRONT DUPLEX
GUEST BEDROOMS
AVAILABLE UPGRADE OPTIONS

UPGRADE TO WOOD FLOORING - STANDARD OR RECLAIMED OPTIONS

SECONDARY BEDROOMS/CLOSETS
STUDY/FLEX ROOM



SCHEUCHER OAK COUNTRY
LACOSTE



SCHEUCHER OAK COUNTRY
PERLA



SCHEUCHER OAK COUNTRY
BIANCA



RECLAIMED

HIGHLANDS RIVERFRONT DUPLEX LAUNDRY

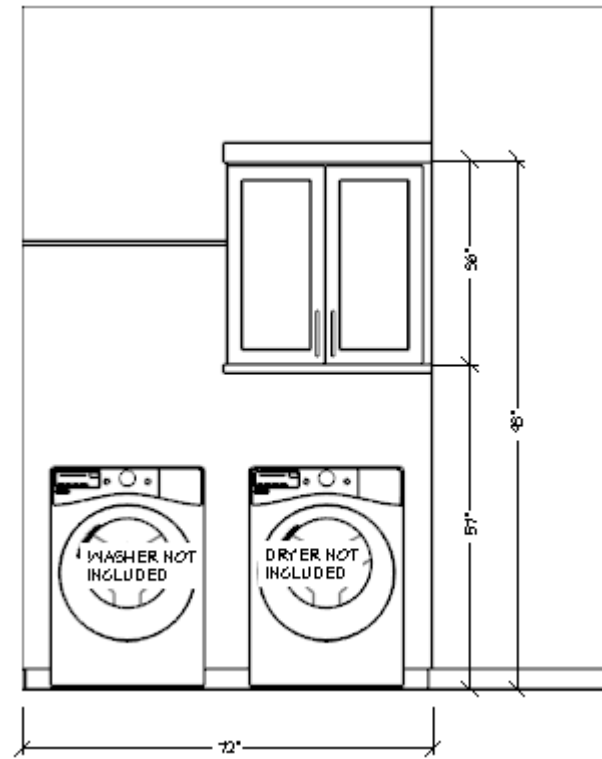
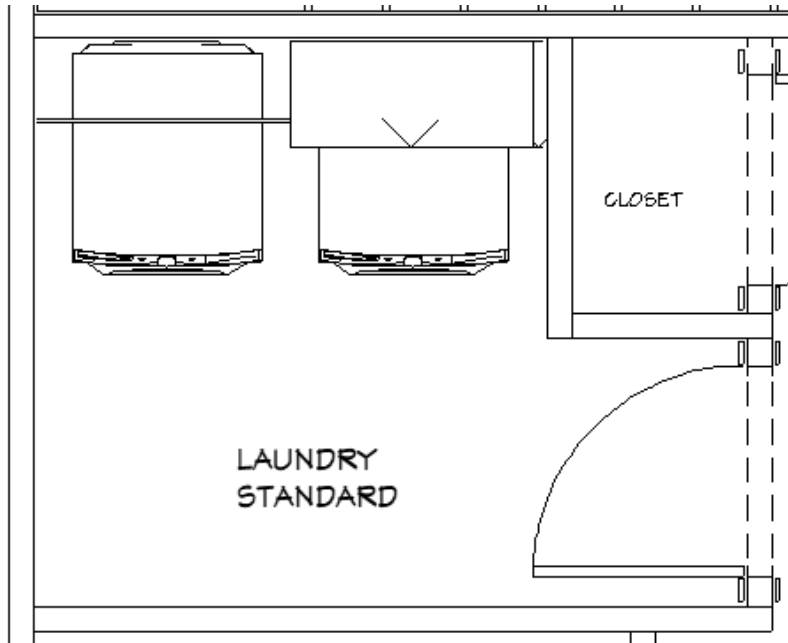

HIGHLANDS RIVERFRONT DUPLEX
LAUNDRY
OPTION 1



PAINTED WHITE
SHAKER

PAINTED WHITE SLAB



EMTEK FREESTONE PULL 6"
Polished Chrome Finish

HIGHLANDS RIVERFRONT DUPLEX
LAUNDRY
OPTION 2



ALDER SHAKER
EBONY OR ESPRESSO



ALDER VENEER SLAB
EBONY OR ESPRESSO



EMTEK WARWICK T KNOB
Flat Black Finish

HIGHLANDS RIVERFRONT DUPLEX
LAUNDRY
OPTION 3



ALDER SHAKER
SMOKE



ALDER VENEER SLAB
SMOKE



EMTEK TRAIL PULL 6"
Satin Nickel Finish

HIGHLANDS RIVERFRONT DUPLEX
LAUNDRY
AVAILABLE UPGRADE OPTIONS

OPTION 1
ADD WALL CABINET, BASE CABINET AND COUNTERTOP ABOVE WASHER/DRYER

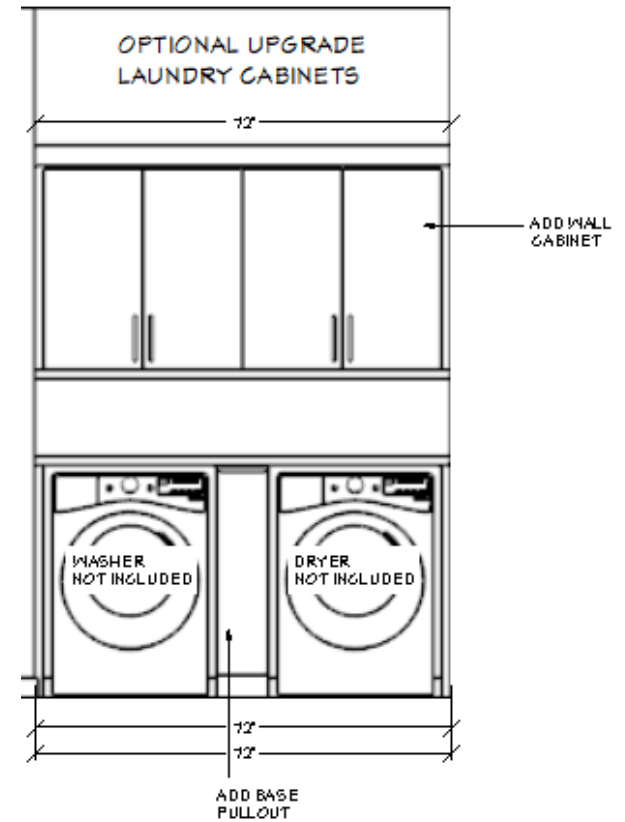
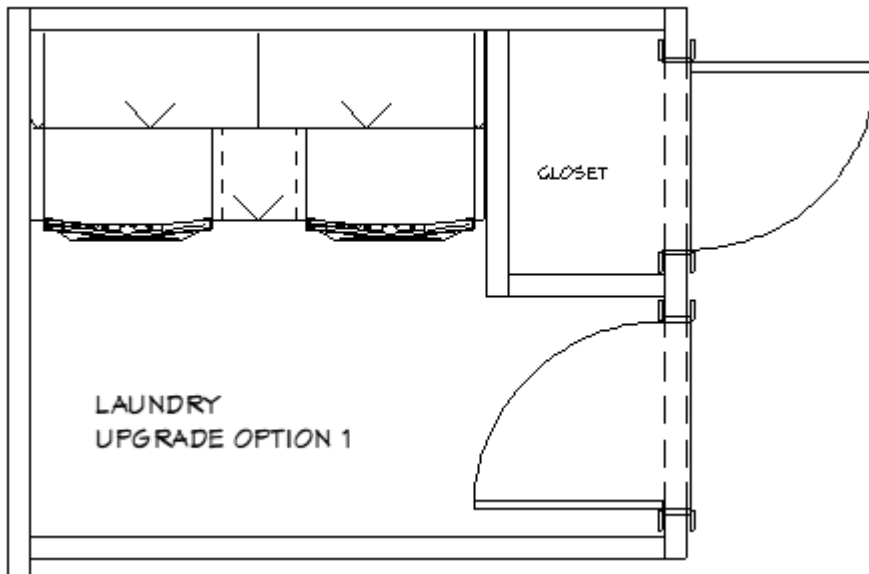

HIGHLANDS RIVERFRONT DUPLEX
LAUNDRY
AVAILABLE UPGRADE OPTIONS

OPTION 1

ADD WALL CABINET, BASE CABINET AND COUNTERTOP ABOVE WASHER/DRYER

COUNTERTOP OPTIONS

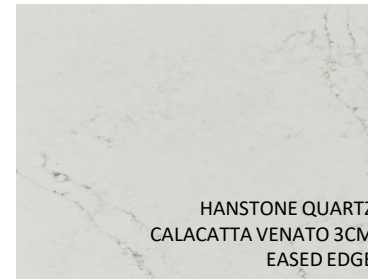
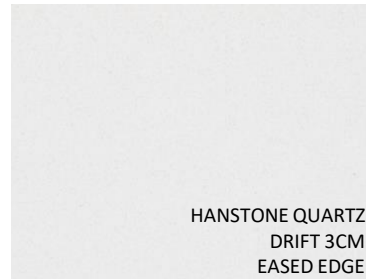
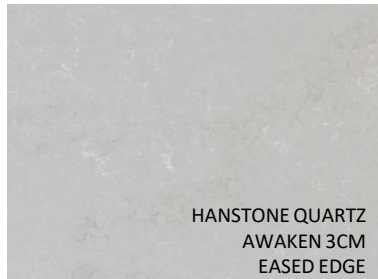

HIGHLANDS RIVERFRONT DUPLEX
LAUNDRY
AVAILABLE UPGRADE OPTIONS

OPTION 2
ADD SINK AND CABINETS FOR OWNER SUPPLIED STACKABLE WASHER/DRYER

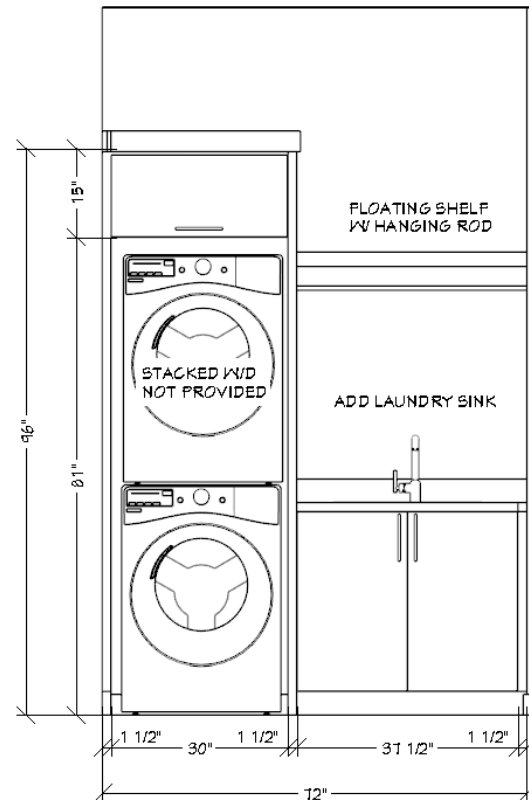
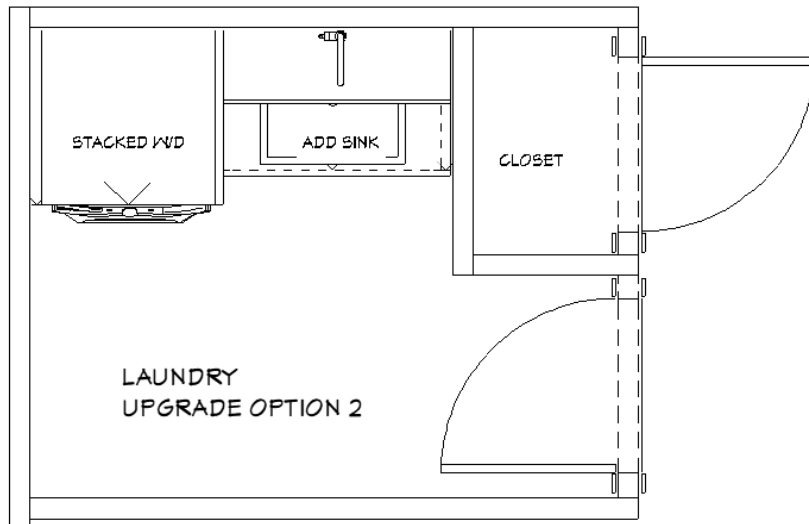

HIGHLANDS RIVERFRONT DUPLEX
LAUNDRY
AVAILABLE UPGRADE OPTIONS

OPTION 2

ADD SINK AND CABINETS FOR OWNER SUPPLIED STACKABLE WASHER/DRYER

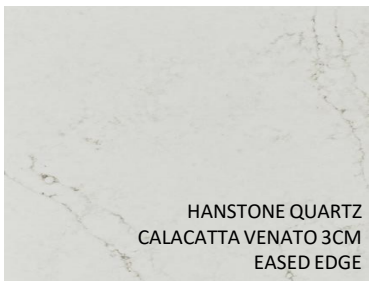
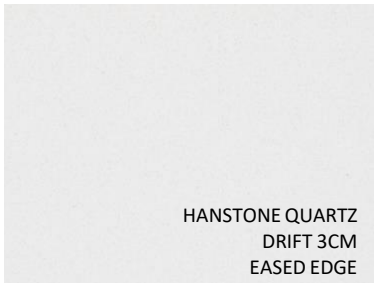
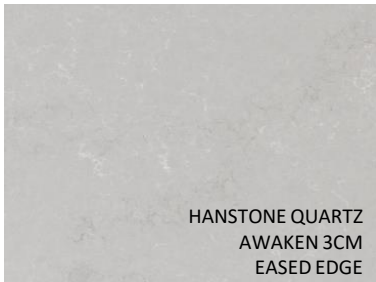

KOHLER SIMPLICE
LAUNDRY FACUET
POLISHED CHROME



KOHLER SIMPLICE
LAUNDRY FACUET
MATTE BLACK



KOHLER SIMPLICE
LAUNDRY FACUET
VIBRANT STAINLESS



KOHLER CAIRN UTILITY
MATTE WHITE

HIGHLANDS RIVERFRONT DUPLEX
COMMON AREAS
OPTION 1



MUDROOM AND LAUNDRY FLOOR TILE
BASALTINE DARK GRAY UPS 12X24
STRAIGHT SET
GROUT TRUFFLE



CARPET – ALL BEDROOMS AND FAMILY ROOM
LAVISH LINEN
WALL STREET



EMTEK MYLES LEVER
SQUARE ROSETTE
POLISHED CHROME FINISH



KNOTTY ALDER INTERIOR DOORS WITH SHALER PROFILE
DOORS AND TRIM STAINED TO COMPLEMENT KITCHEN CABINETS

HIGHLANDS RIVERFRONT DUPLEX
COMMON AREAS
OPTION 2



MUDROOM AND LAUNDRY FLOOR TILE
NOTORIOUS SUSPENSE UPS 12X24
STRAIGHT SET
GROUT WALNUT



CARPET – ALL BEDROOMS AND FAMILY ROOM



EMTEK FREESTONE LEVER
MODERN RECTANGLE ROSETTE
MATTE BLACK FINISH



KNOTTY ALDER INTERIOR DOORS WITH SHALER PROFILE
DOORS AND TRIM STAINED TO COMPLEMENT KITCHEN CABINETS

HIGHLANDS RIVERFRONT DUPLEX COMMON AREAS OPTION 3



MUDROOM AND LAUNDRY FLOOR TILE
FEEL WHITE 12X24
STRAIGHT SET
GROUT SNOW WHITE

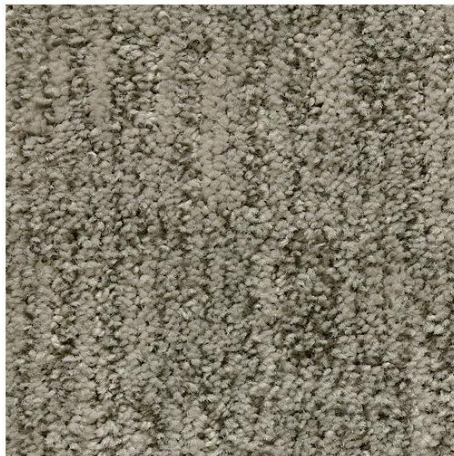

CARPET – ALL BEDROOMS AND FAMILY ROOM
LAVISH LINEN
UPTOWN TAUPE



EMTEK HELIOS LEVER
MODERN RECTANGLE ROSETTE
SATIN NICKEL FINISH



KNOTTY ALDER INTERIOR DOORS WITH SHALER PROFILE
DOORS AND TRIM STAINED TO COMPLEMENT KITCHEN CABINETS

HIGHLANDS RIVERFRONT DUPLEX PAINT COLOR SUGGESTIONS



GOSSAMER VEIL
SW 9165



MINDFUL GRAY
SW 7016

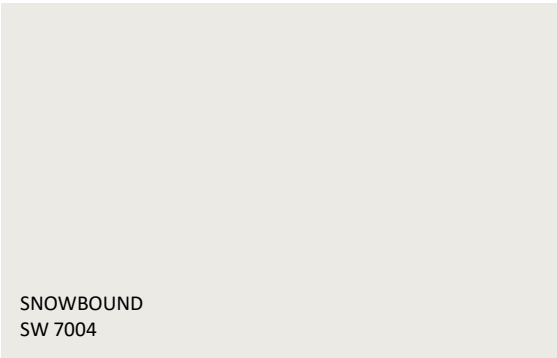

SNOWBOUND
SW 7004



AGREEABLE GRAY
SW 7029

HIGHLANDS RIVERFRONT DUPLEX
UPPER LEVEL FAMILY ROOM
AVAILABLE UPGRADE OPTIONS

UPGRADE TO WOOD FLOORING - STANDARD OR RECLAIMED OPTIONS

UPPER LEVEL FAMILY ROOM

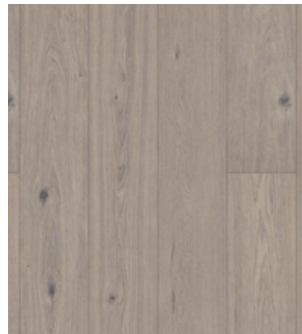

SCHEUCHER OAK COUNTRY
LACOSTE



SCHEUCHER OAK COUNTRY
PERLA

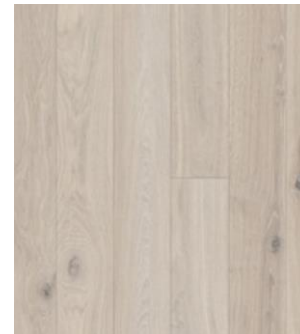

SCHEUCHER OAK COUNTRY
BIANCA



RECLAIMED

HIGHLANDS RIVERFRONT DUPLEX UPPER LEVEL FAMILY ROOM AVAILABLE UPGRADE OPTIONS

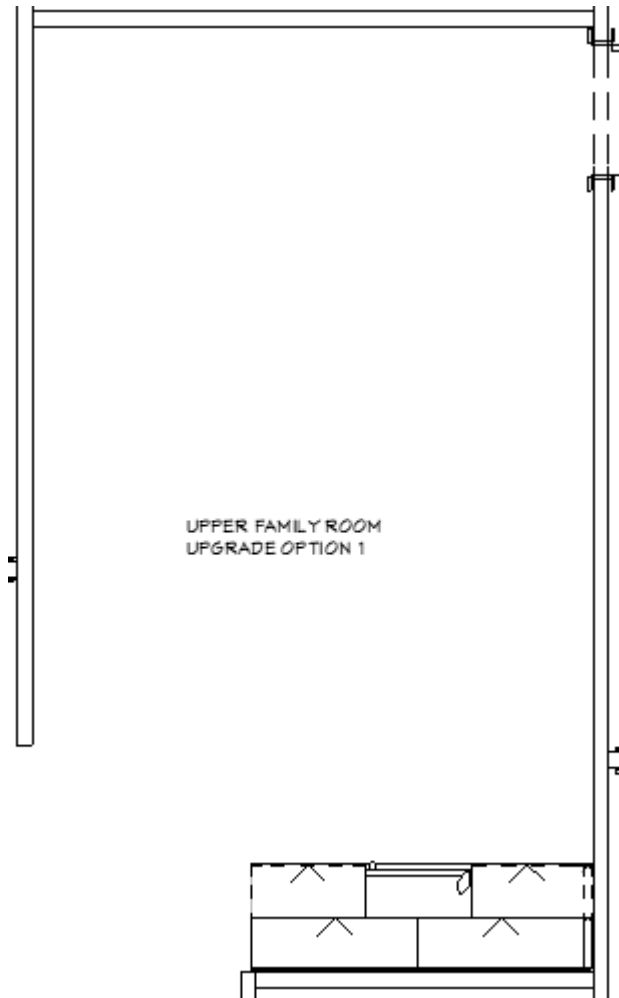

OPTION 1
ADD CABINETRY, BEVERAGE CENTER AND FULL HEIGHT QUARTZ BACKSPLASH
FINISHES TO MATCH KITCHEN SELECTIONS

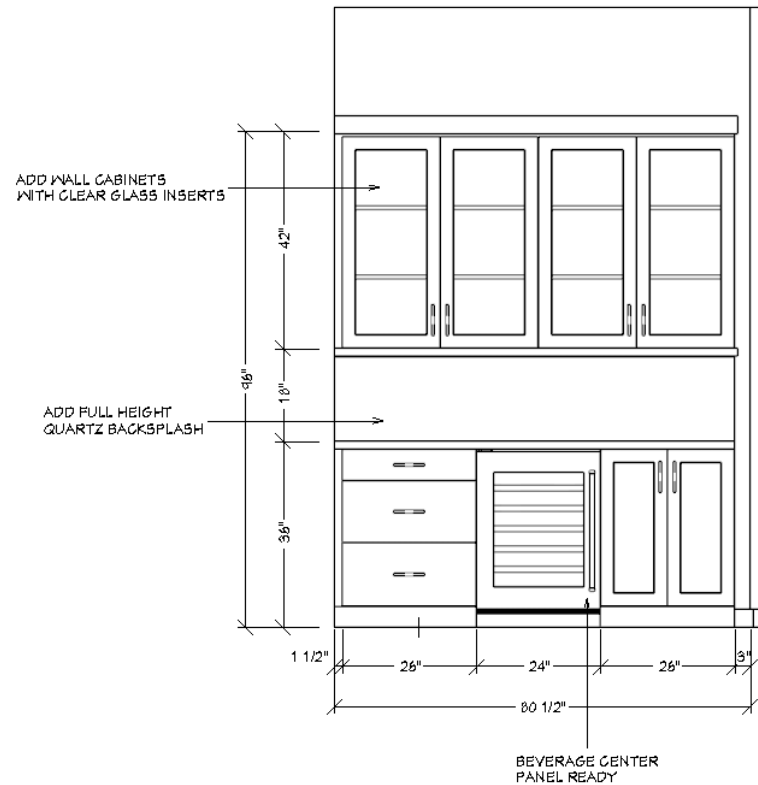

HIGHLANDS RIVERFRONT DUPLEX
UPPER LEVEL FAMILY ROOM
AVAILABLE UPGRADE OPTIONS

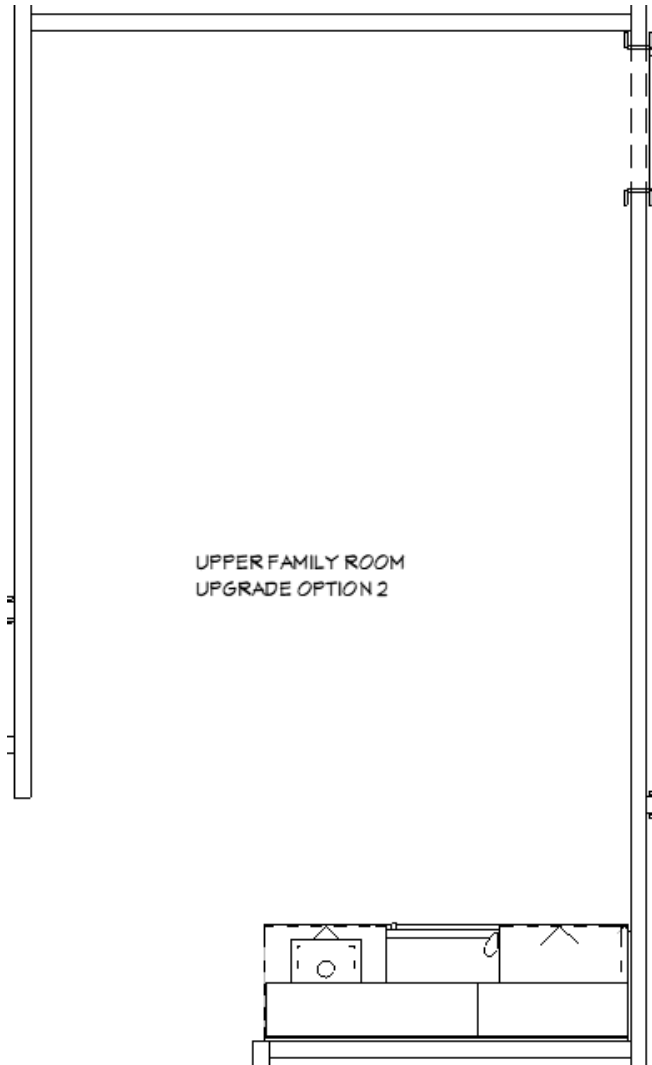

OPTION 2
ADD OPEN SHELVES, BEVERAGE CENTER AND SINK
FINISHES TO MATCH KITCHEN SELECTIONS

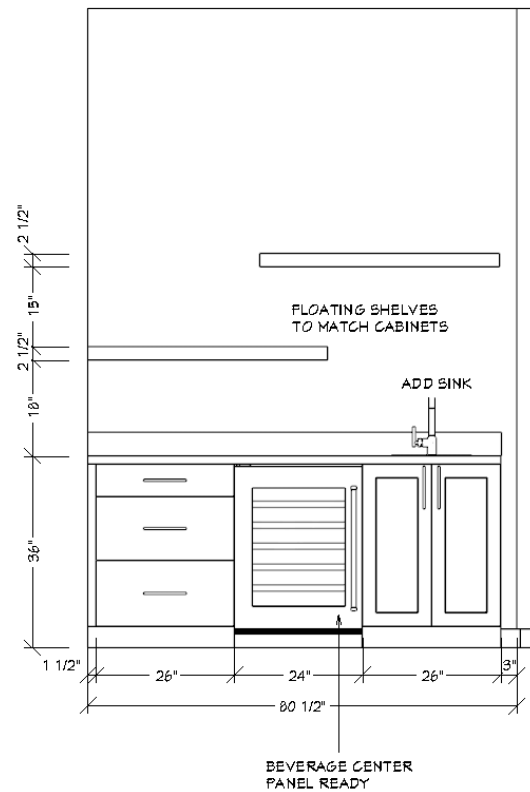

HIGHLANDS RIVERFRONT DUPLEX
UPPER LEVEL FAMILY ROOM
OPTION 1



PAINTED WHITE
SHAKER

PAINTED WHITE SLAB

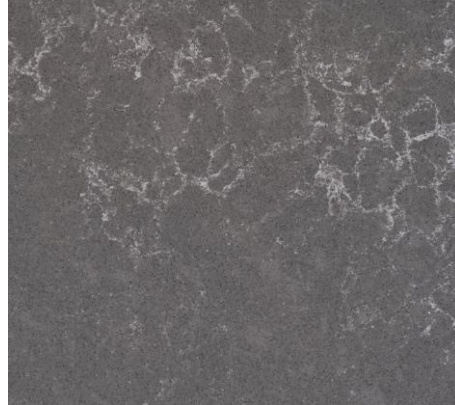

HANSTONE QUARTZ
EMBRACE 3CM
EASED EDGE



Kohler Cruie Bar
Matte Black Finish

EMTEK WARWICK PULL 6"
Flat Black Finish



Kohler Cairn Bar
Matte Black Finish

HIGHLANDS RIVERFRONT DUPLEX
UPPER LEVEL FAMILY ROOM
OPTION 2



ALDER SHAKER
EBONY OR ESPRESSO

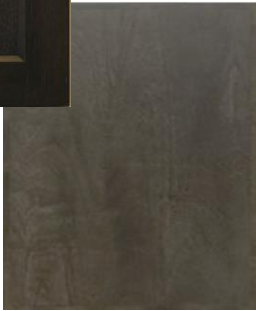

ALDER VENEER SLAB
EBONY OR ESPRESSO



HANSTONE QUARTZ
CALACATTA EXTRA 3CM
EASED EDGE



Kohler Purist Bar
Vibrant Stainless Finish



EMTEK EDGE PULL 6"
Flat Black Finish



Kohler Strive Bar
Stainless

HIGHLANDS RIVERFRONT DUPLEX
UPPER LEVEL FAMILY ROOM
OPTION 3



ALDER SHAKER
SMOKE



ALDER VENEER SLAB
SMOKE



HANSTONE QUARTZ
MERCER 3CM
EASED EDGE



Kohler Grase Bar
Vibrant Stainless Finish



EMTEK FREESTONE PULL 6"
Satin Nickel Finish



Kohler Strive Vault
Stainless

HIGHLANDS RIVERFRONT DUPLEX PATIO

PATIO LAYOUT OPTION 1

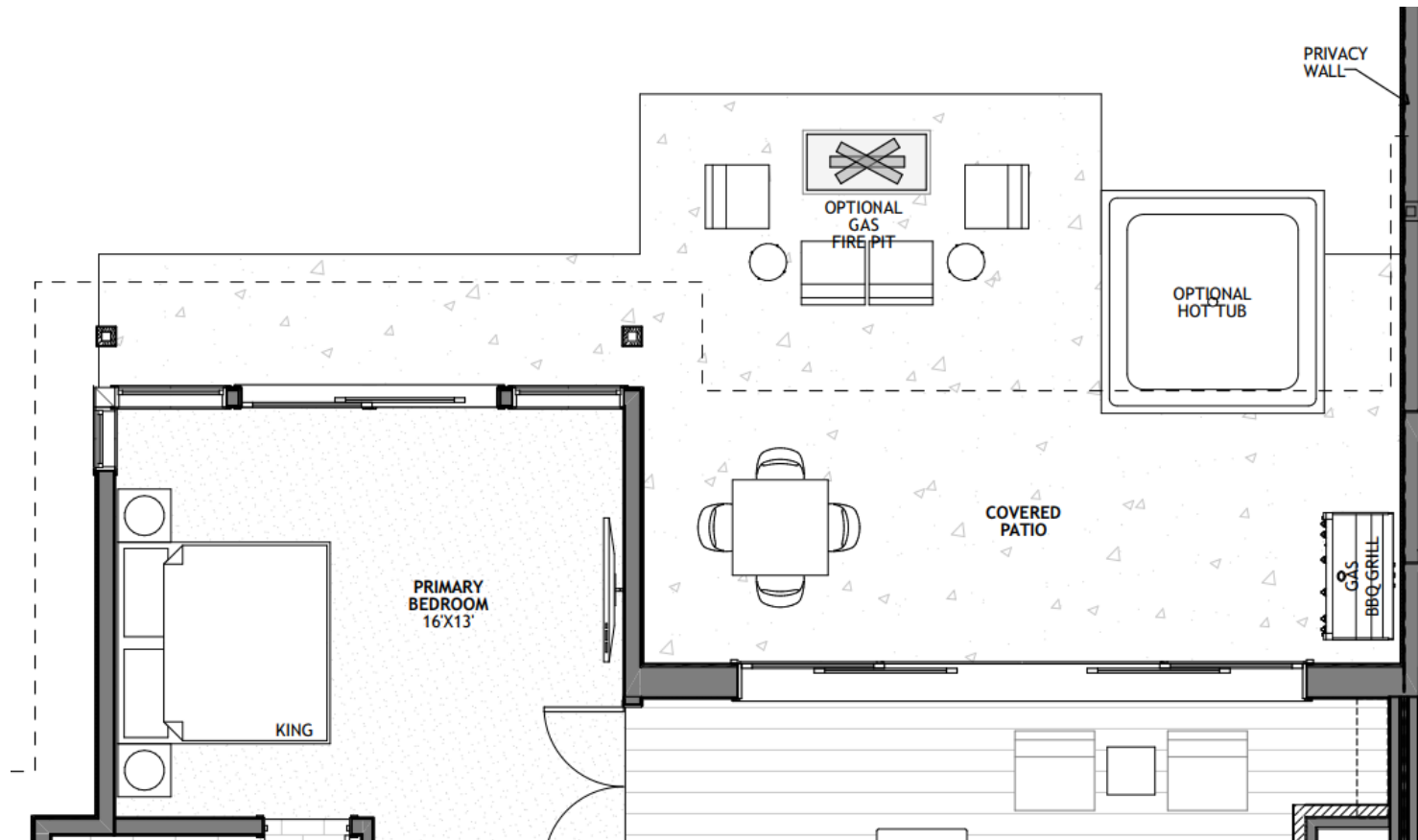

HIGHLANDS RIVERFRONT DUPLEX PATIO

PATIO LAYOUT OPTION 2

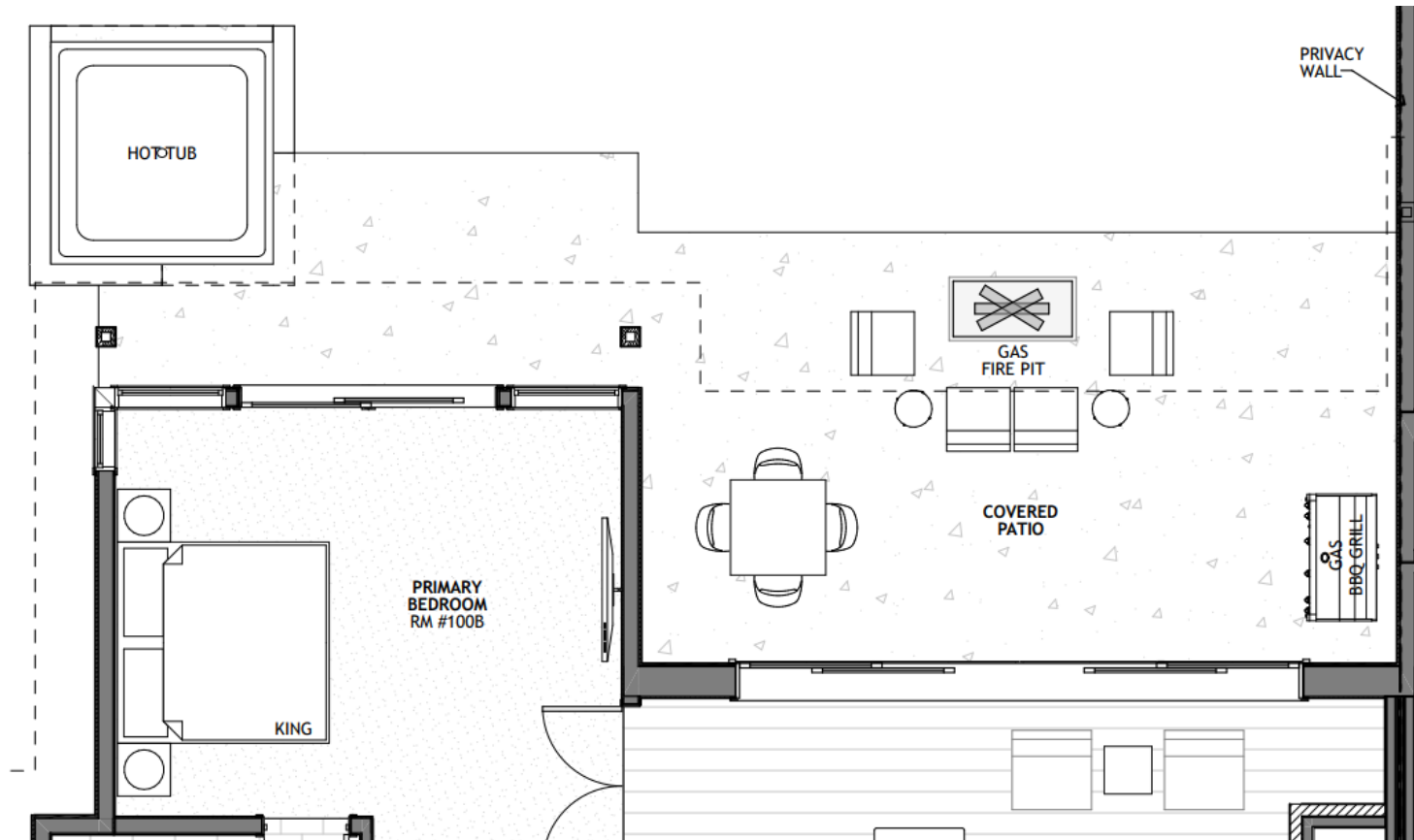

HIGHLANDS RIVERFRONT DUPLEX PATIO AVAILABLE UPGRADE OPTIONS



HOT TUB SELLER OPTION – HOTSPRINGS RHYTHM SPA 7' X 7'

Includes hot tub in standard color scheme, cover and cover lifter, installation, electrical provisions, permit fees, and crane fees

HOT TUB – BUYER OPTION

Buyer provides their own hot tub, installation, accessories and crane. Includes Coordination fee, electric breaker and connection fee only

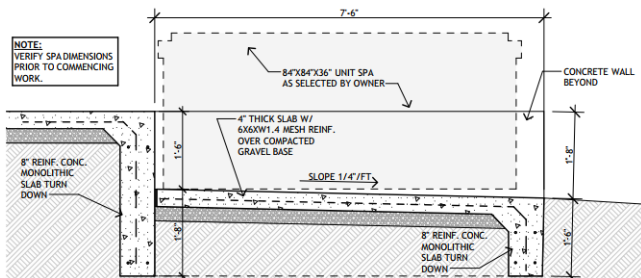

SEMI RECESS HOT TUB INTO THE PATIO



TAVOLA 8 FIRE TABLE



ADD TWO ELECTRIC PATIO HEATERS

HIGHLANDS RIVERFRONT DUPLEX AVAILABLE UPGRADE OPTIONS



GARAGE FLOOR EPOXY COATING

This treatment is applied to the garage floor to give extra durability, slip resistance, and to make garage floor cleanup easier.

Multiple color options are available.

IN-WALL HUMIDIFIER

Aprilaire 600 is a self-contained, through-wall evaporative humidification system providing optimum relative humidity throughout the winter, when ambient humidity is lowest. This system is designed specifically for homes using high-efficiency heating systems, like in-floor radiant heat, that do not utilize ductwork. The unit is plumbed into the home's domestic water system and does not require re-filling, in contrast to a standalone humidifier, adding up to 13 gallons of moisture to the air per day.

ADD FLO BY MOEN WHOLE HOUSE SMART WATER MONITOR AND SHUTOFF

The Flo Smart Water Monitor and Shutoff is a revolutionary smart home water security system that features a suite of products to protect your home from water damage and leaks. The Flo Smart Water Monitor and Shutoff monitors your entire water supply system for leaks and vulnerabilities.

ADD KEYED LOCK TO ANY INTERIOR SWING DOOR

The owner may select to add a keyed lock to any interior swing door closet to create an "owner's closet." This is useful should the owner choose to rent the property in the future and wish to keep some closet space off-limits to potential guests.

ADD OWNER'S STORAGE CLOSET TO GARAGE

The garages planned in the Highlands Riverfront duplex homes allow for a locking, single door closet to be built-in to the garage during construction. As a standard, the closet does not feature built-in shelving to allow for storage of tall items, like skis or snowboards.

PAINTED ACCENT WALL OR DIFFERENT CEILING COLOR

The owner may request a painted accent wall or differing ceiling color, to be determined during the interior finish selection process. The upgrade fee is assessed on a per-instance basis, meaning that each additional accent wall or differing ceiling color is an additional selection.

PAINTED BASEBOARD AND CASING

Painted baseboard and casing throughout home to match wall color selection. Door slabs and window jambs will be stained

HIGHLANDS RIVERFRONT DUPLEX AVAILABLE UPGRADE OPTIONS



ALTITUDE CONTROL SYSTEM

The OxySpace oxygen enrichment system works by capturing oxygen from the ambient air and redistributing it to various locations inside your home, eliminating the need for pressurized oxygen tanks to help overcome the effects of high altitude. The system is custom designed to increase the amount of oxygen in a given room, simulating a lower elevation. The machines shown below are installed in the garage, and the enriched air is fed to small, discreet outlets in the designated rooms. Dimensions: 24"x24"x17". The number of units required will depend on the number of rooms that will have oxygen enrichment.

Additional information is available at altsol.com

SOLAR PV AND/OR POWER BACK-UP SYSTEM

Buyer will work direct with provider for purchase of system and seller will charge a coordination fee

*CHANGES TO ELECTRICAL SPECIFICATIONS MAY REQUIRE UPGRADES TO THE HOME'S ELECTRICAL SERVICE

HIGHLANDS RIVERFRONT DUPLEX AVAILABLE UPGRADE OPTIONS

ADDITIONAL RECESSED LIGHT, PROVISION FOR SURFACE-MOUNTED FIXTURE OR POWER OUTLET

At your request we will be happy to add an additional recessed can light, power outlet beyond our standards, or a provision for a surface-mounted fixture such as a chandelier or pendant light, to be installed by owner after closing. Your election of this upgrade option must be provided prior to the finish selection deadline.

UPGRADE EXISTING OUTLET TO USB EQUIPPED OUTLET

Any non-GFI outlet can be equipped with USB charging capability at your request. This eliminates the need for a wall charger, allowing the user to plug any USB-compatible device directly into the wall outlet utilizing the appropriate charging cable.

ADD SECOND 220V OUTLET IN GARAGE FOR AN ADDITIONAL ELECTRIC VEHICLE CHARGER

One EV outlet is included in the standard finish for the home.

ADD 110V FLOOR OUTLET

Cannot be added after foundation slab is poured

*CHANGES TO ELECTRICAL SPECIFICATIONS MAY REQUIRE UPGRADES TO THE HOME'S ELECTRICAL SERVICE

All upgrades represent changes to the scope of work and will consequently extend the completion deadline of the home. All offerings are subject to change based on supplier pricing and availability and are subject to an 18% Developer's fee per contract terms. Final pricing will be verified prior to the approval of any upgrade requests. The upgrades listed are inclusive of additional permits and Developer's fee. All upgrade requests must be submitted by the finish selection deadline. No further upgrades or changes can be accommodated after that time.

HIGHLANDS RIVERFRONT DUPLEX

AVAILABLE UPGRADE OPTIONS

CLOSET UPGRADES – PRIMARY OPTION 1

STANDARD CONFIGURATION IS A SINGLE ROD AND SHELF

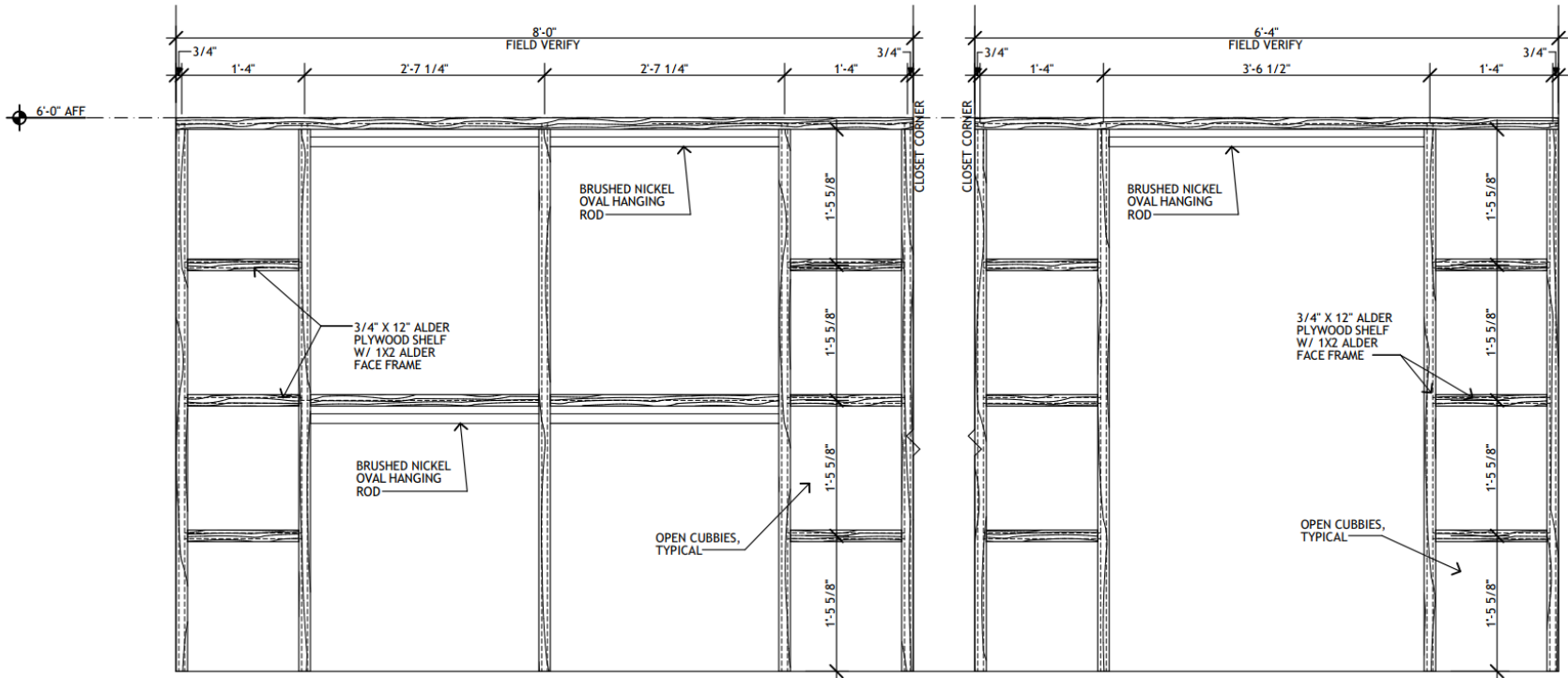

HIGHLANDS RIVERFRONT DUPLEX

AVAILABLE UPGRADE OPTIONS

CLOSET UPGRADES – PRIMARY OPTION 2

STANDARD CONFIGURATION IS A SINGLE ROD AND SHELF

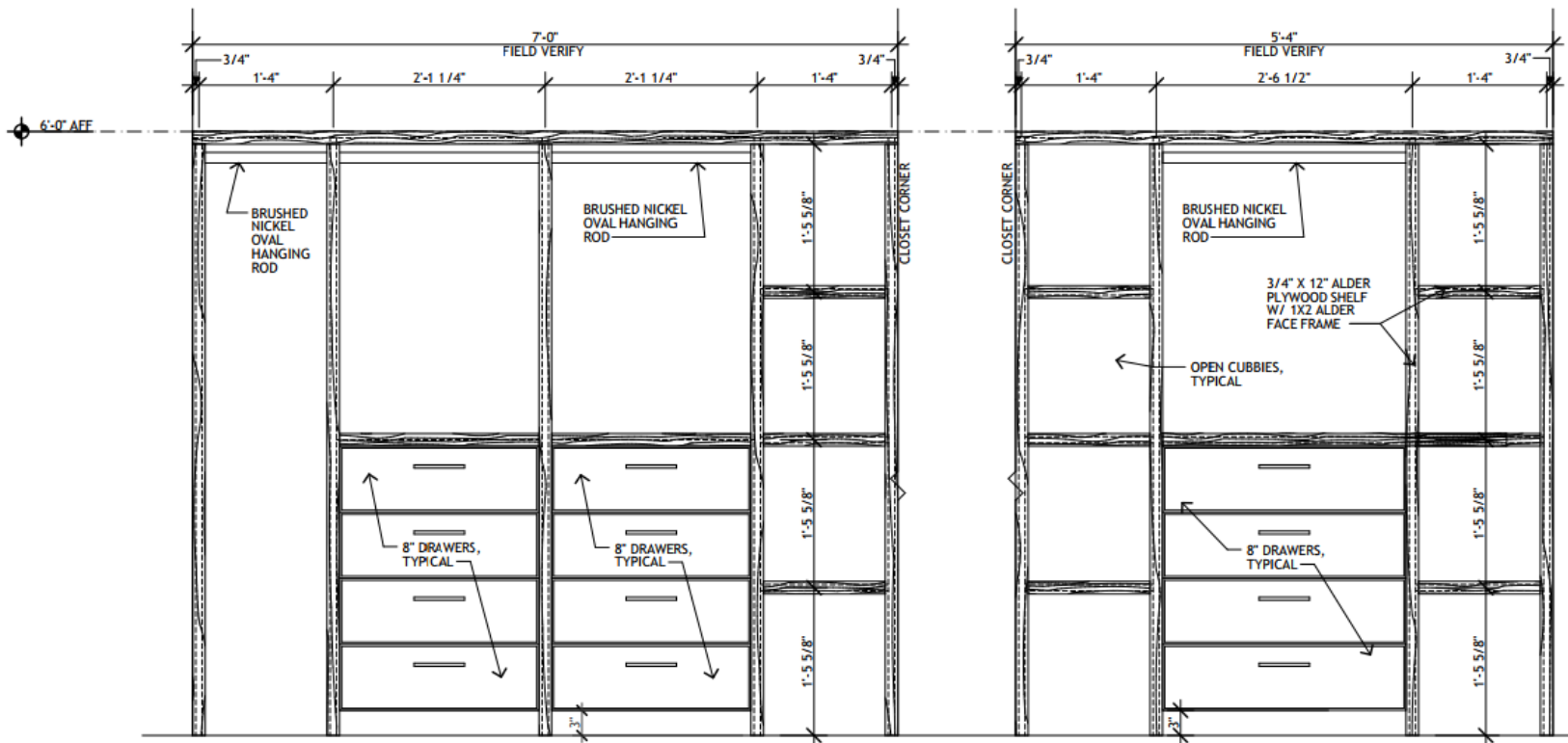

HIGHLANDS RIVERFRONT DUPLEX

AVAILABLE UPGRADE OPTIONS

CLOSET UPGRADES – MINI PRIMARY OPTION 1

STANDARD CONFIGURATION IS A SINGLE ROD AND SHELF

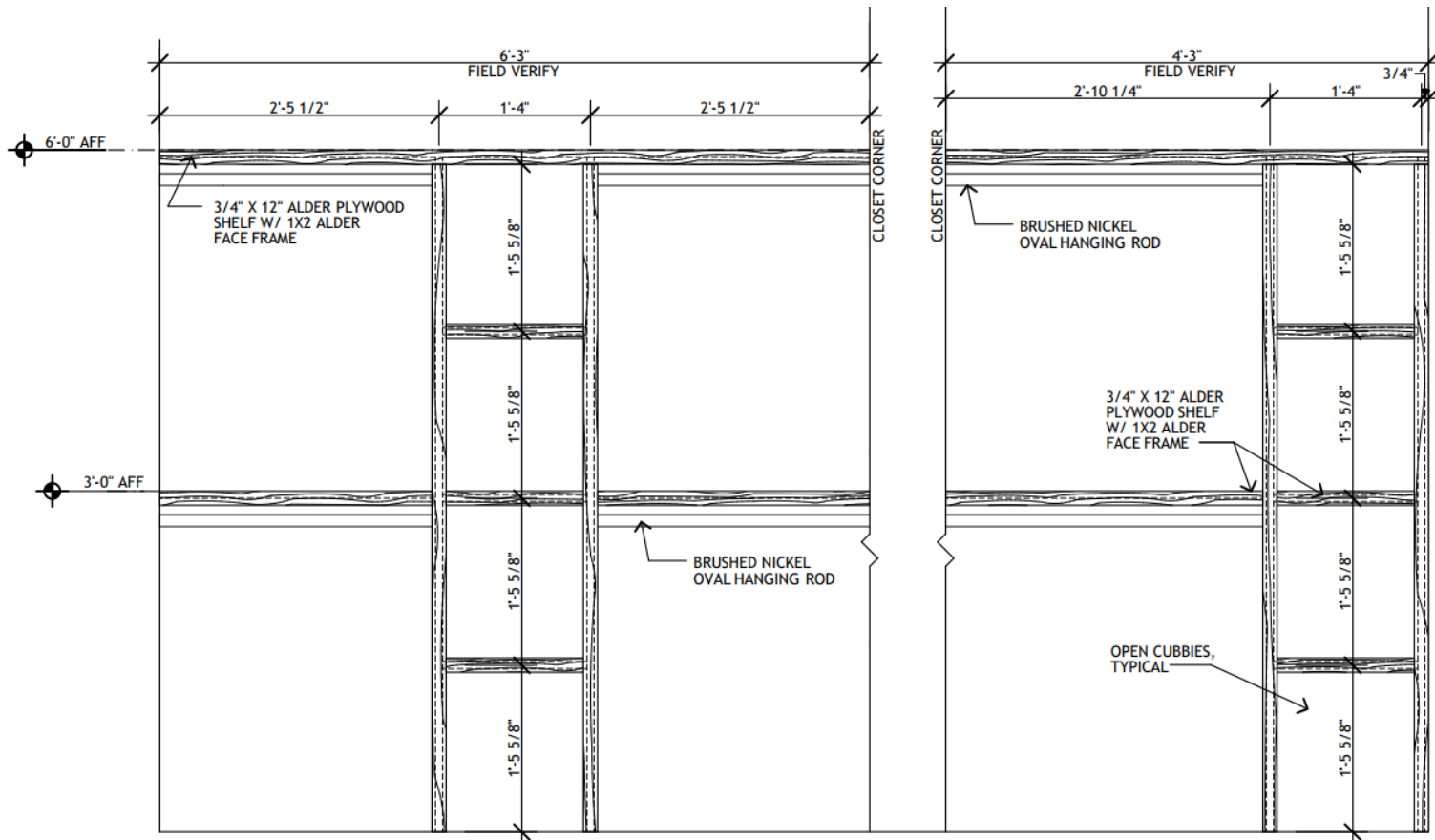

HIGHLANDS RIVERFRONT DUPLEX

AVAILABLE UPGRADE OPTIONS

CLOSET UPGRADES – MINI PRIMARY OPTION 2

STANDARD CONFIGURATION IS A SINGLE ROD AND SHELF

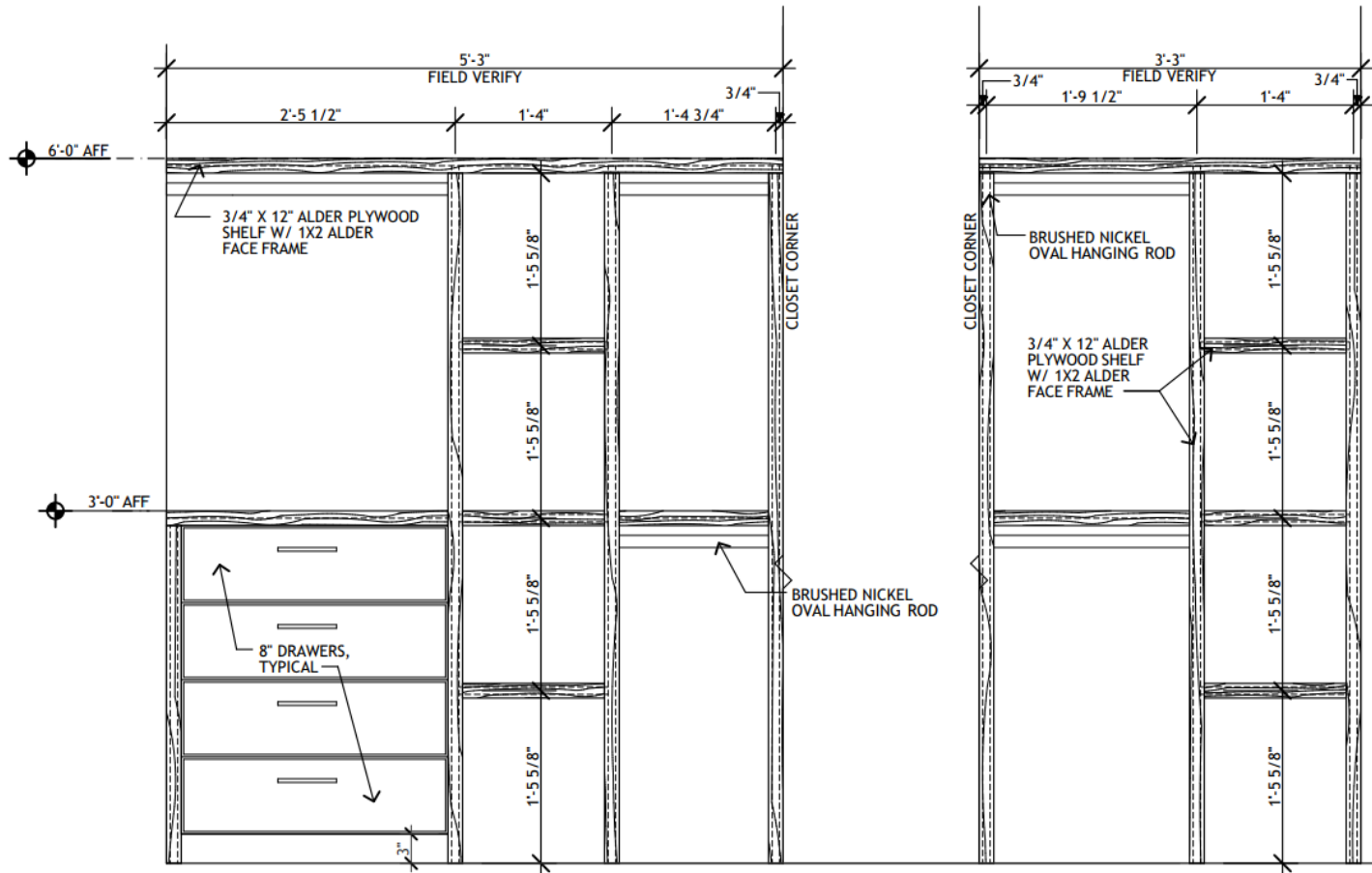

HIGHLANDS RIVERFRONT DUPLEX AVAILABLE UPGRADE OPTIONS

CLOSET UPGRADES – BEDROOM 3 OPTION 1 STANDARD CONFIGURATION IS A SINGLE ROD AND SHELF

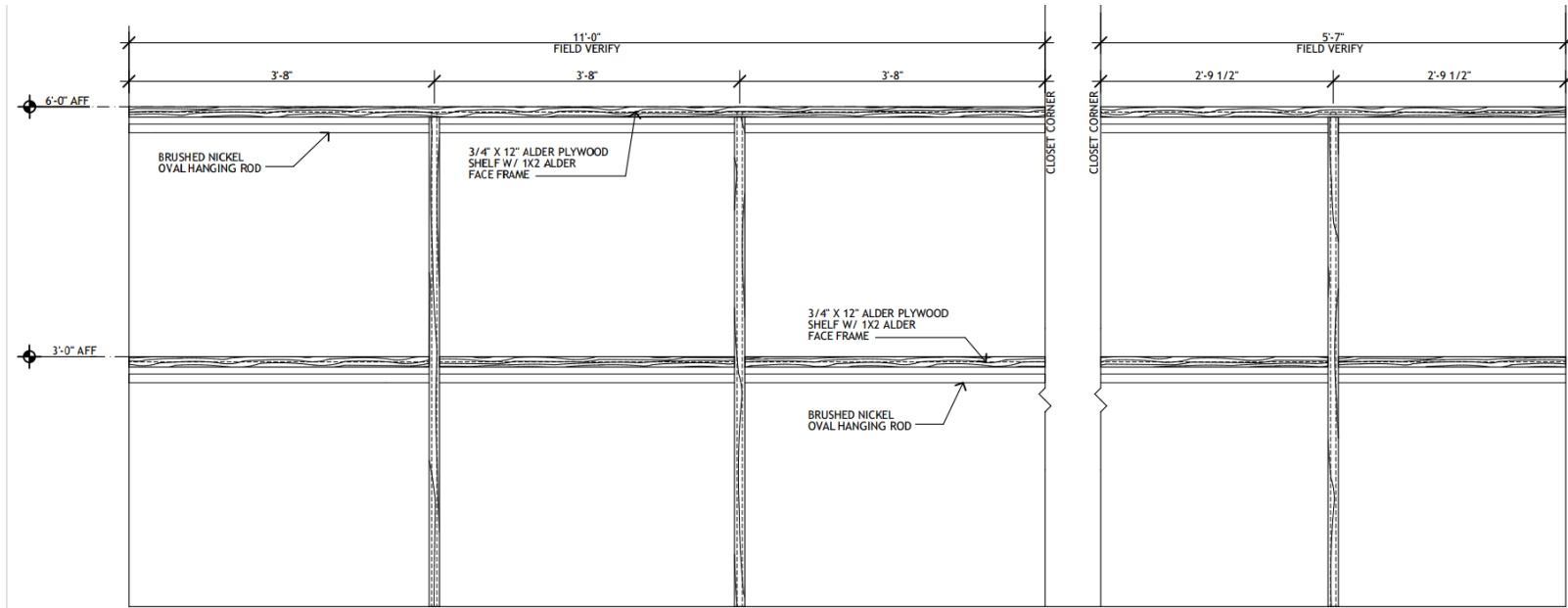

HIGHLANDS RIVERFRONT DUPLEX AVAILABLE UPGRADE OPTIONS

CLOSET UPGRADES – BEDROOM 3 OPTION 2 STANDARD CONFIGURATION IS A SINGLE ROD AND SHELF

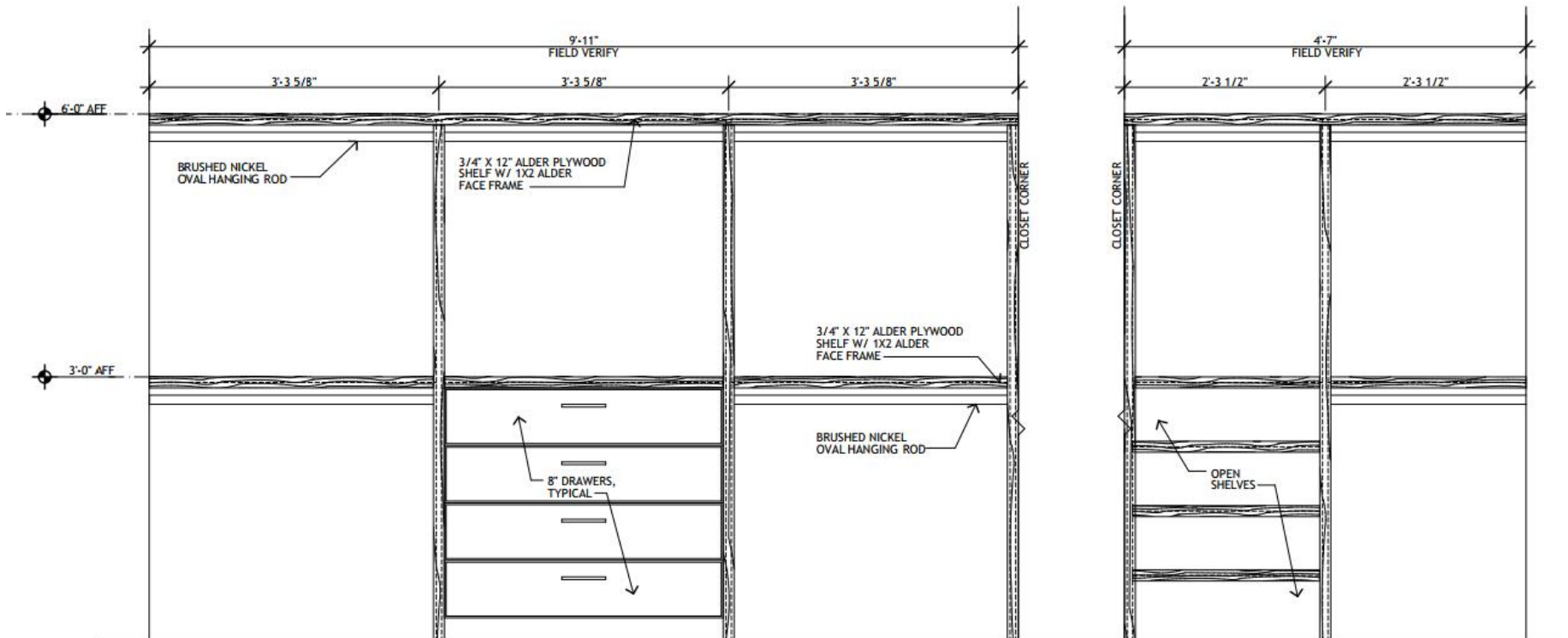

HIGHLANDS RIVERFRONT DUPLEX AVAILABLE UPGRADE OPTIONS

CLOSET UPGRADES – BEDROOM 4 OPTION 1 STANDARD CONFIGURATION IS A SINGLE ROD AND SHELF

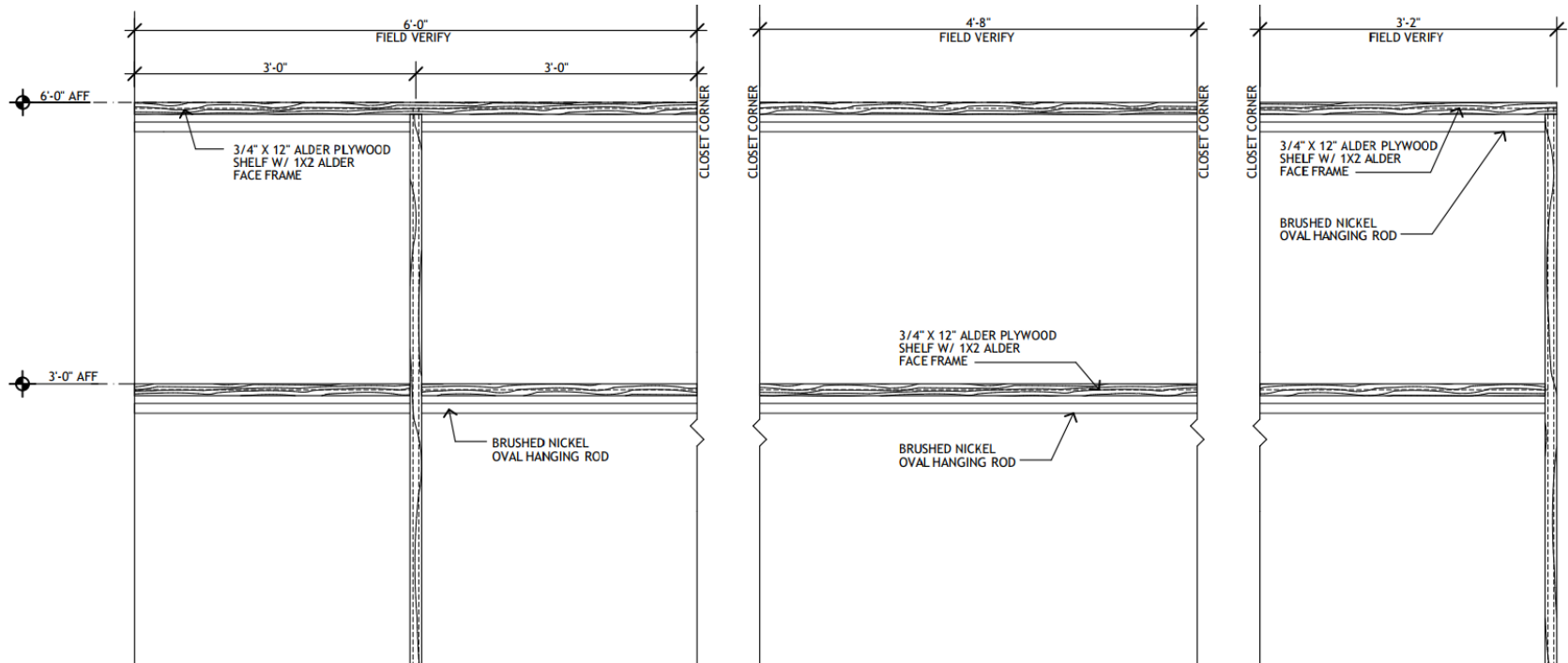

HIGHLANDS RIVERFRONT DUPLEX

AVAILABLE UPGRADE OPTIONS

CLOSET UPGRADES – BEDROOM 4 OPTION 2

STANDARD CONFIGURATION IS A SINGLE ROD AND SHELF

